

# 1969 Camaro

## INSTALLING THE CAP-3369

*This system is designed for installation in factory Heater Only vehicles.*



1201 Forum Way South, Fort Worth, TX 76140  
(817) 531-2665 or FAX 531-3257

This system is a combination heat/cool defrost system. Appearance is neat, and performance is unsurpassed, Installation is straightforward, requiring basic mechanic tools.

To be effective, an air conditioner must remove heat from the air in a vehicle faster than it is added. To reduce the "heat added" seal all holes in the fire wall, insulate the roof, fire wall, and floorboards and insure that all weather stripping around doors, windows and fresh air inlets are in good shape. Window tinting will also reduce "heat added" to the vehicle.

For maximum cooling performance a clutch style or steel six-blade fan should be installed with shroud if possible. We do not recommend flex fans. Another alternative, and a definite plus for any system is the addition of an electric condenser fan, dedicated to the A/C System. If the vehicle is equipped with only an electric radiator fan, it MUST be wired to engage with the A/C system. A/C head pressure will increase much faster than the engine temperature. A/C head pressure is generally associated with airflow and can damage the compressor and other components. Steel Fan Blades and High Quality Electric Radiator & Condenser Fans are available from Old Air Products, at a very reasonable cost.

When a/c kit is installed on vehicles with V8 engines the hose routing will be neater and easier with a passenger side compressor and driver side alternator. Both brackets for most engines are available from Old Air Products.

### PREPARE VEHICLE FOR INSTALLATION

- 1) Read through the instructions prior to starting Installation.
- 2) Make sure the A/C system, brackets & control package are correct for your vehicle application. If you have any questions regarding the correct application of parts included with this system contact your supplier or Old Air Products before proceeding with installation.
- 3) Disconnect the battery, Remove Original Heater Assembly, defroster duct, Heater Cover, Dash Pad, Instrument Panel, Vent ducts (both Passenger & Driver Side), Glove Box & Glove Box Door.

### UNIT INSTALLATION

- 1) Install Fresh air block off covers on both driver & passenger side. (Photos 1A & 1B)  
*IMPORTANT NOTE: Make sure the seals in kick panel vents are in good condition. Cracked or bad seals should be replaced, Bad seals will allow outside air into the vehicle significantly reducing the amount of cooling capacity of the A/C system.*



Photo 1A - Passenger Side Fresh Air Cover



Photo 1B - Driver Side Fresh Air Cover

2) Install Fresh Air / Block off plate in factory blower motor opening located on passenger side behind inner fender area. (Photo 2)

3) Align defrost outlets with dash openings & attach with #10 X 1/2 Hex Screws provided.

4) Remove lip around large rectangular opening in fire wall.

5) Align cover plate with factory fire wall holes, the bottom passenger side hole is common for both A/C and Heater Only vehicles, at least 1 other hole in fire wall will line up with holes in plate. (Photo 3)

6) Temporarily Attach cover plate to fire wall.

7) Mark/scribe location of remaining holes in cover plate.

8) Remove cover plate & drill holes at marked locations.

*Tip: If you prefer a clean fire wall appearance cover plate can be welded to the fire wall and smoothed at the edges so mounting bolts will not be visible from the engine compartment.*

9) Place insulation/gasket material on fire wall side of cover plate.

*Tip: If cover plate is welded in for a smooth fire wall put insulation/gasket material between unit & inside of fire wall.*

10) Hold unit in position & place mounting studs & fittings through holes in fire wall (Photo 4), Install fire wall cover plate, secure using 2) 1/4-20 Nuts w/washers on mounting studs & rubber O-ring w/ hex nuts on A/C & Heater Fittings. (Photo 3)

11) Install upper unit support bracket (Photo 5) & blower motor support bracket with #1-32 X 1/2" screws (Photo 6)

**Caution:** When securing screws to blower housing make sure screws do not interfere with blower wheel

12) Install Drain Tube:

- a) Choose a location in floor below unit, check engine side of fire wall for obstructions.
- b) Drill 1-1/4 hole.
- c) Insert Grommet
- d) route 1/2" drain tube from unit through grommet using 90 degree fitting supplied.

13) Mount relays to fire wall or other convenient location.

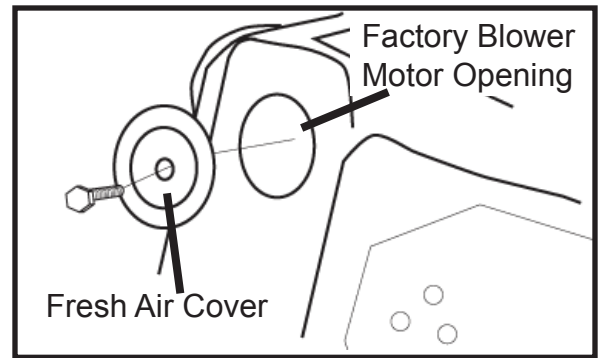

Photo 2 - Fresh Air / Blower Motor Block-off

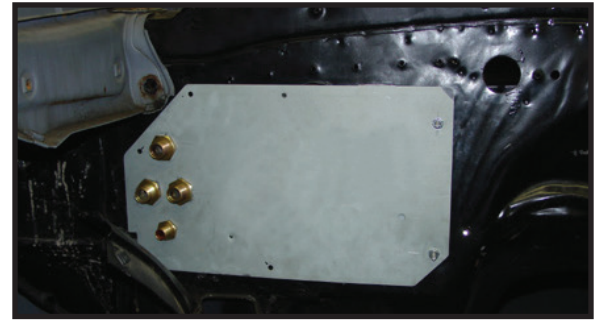

Photo 3 - Firewall Block-off Plate



Photo 4 - Install Unit to Firewall



Photo 5 - Install Unit Support Bracket



Photo 6 - Blower Motor Support Bracket

14) Attach shorter cable from DEFROST lever on control to defrost/floor air lever on unit.

15) Attach longest cable from HOT/COLD lever on control to diverter door lever on unit.

16) Plug matching plug from wire harness onto blower switch.

17) Connect red wire marked 12+ IGN to a key on power source.

18) Connect Red wire marked 12+ Battery to a 12V Power source.

**NOTE:** For the following steps It is very important to have a good clean ground connection. A loose or dirty ground wire may cause excessive amperage draw, intermittent blower operation, premature switch failure and damage to the wire harness.

19) Connect Black (-) wire from blower motor to a solid clean point of contact on the vehicle body using the hex screw and star washer provided.

20) Route Brown & Black wires for vacuum solenoid through fire wall, connect wires to solenoid & mount solenoid to outside of fire wall. Connect Black (-) wire from solenoid to a solid clean point of contact on the vehicle body using the hex screw and star washer provided. (Vacuum hose will be connected during heater valve installation)

21) Route Green wire marked CLUTCH / PRESSURE SWITCH through fire wall. (This wire will be connected later when under hood components are installed).

22) Attach adapters to factory side louvers,

23) Mount dual center louver to bottom edge of dash.

24) Route duct hose from unit to defrost outlets & dash louvers, Stretch duct hose to maximum length & cut to length as required for installation.

**Installation Tip:** When routing duct hose avoid making sharp bends or pinching the hose, this will cause airflow restrictions that may result in reduced overall system performance.



Photo 7 - Defrost Cable

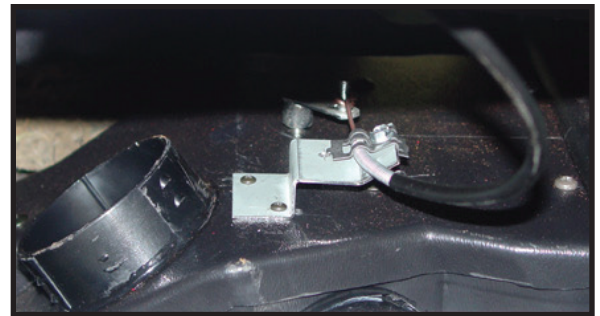

Photo 8 - HOT / COLD Cable

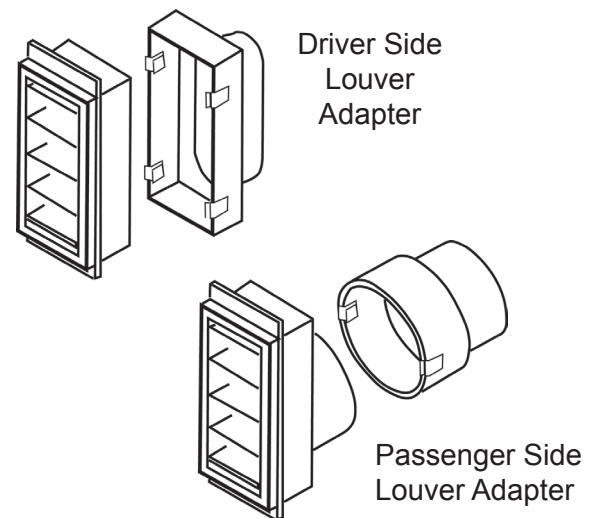

Photo 9 - Louver Adapters

**Installation Tip:** For a more original appearance install an optional factory style A/C Center louver & Factory A/C dash pad available from Old Air Products.

## COMPRESSOR & BRACKET

1) Locate the compressor and the mounting bracket. Refer to the instructions in the bracket hardware bag for installation. During installation the compressor may be mounted with fittings pointed to either side for easier hose routing but **DO NOT MOUNT COMPRESSOR UPSIDE DOWN**.

**NOTE:** New compressors from Old Air Products are filled with adequate oil for the complete system.

## CONDENSER & DRIER INSTALLATION

**NOTE:** Condenser & Drier are pressurized with nitrogen - remove caps slowly to release nitrogen charge.

**CAUTION:** A backup wrench must be used on hold both sides of fittings to avoid damage to condenser or tubes.

1) Align condenser with factory mounting holes, fittings should point towards passenger side of vehicle with larger fitting at top, insert rubber well nuts in factory mounting holes & attach condenser with 4) 1/4" washers & 4) 1/4-20 X 1 hex head bolts. (Photo 11)

2) Install condenser to drier jumper tube to lower fitting on condenser, connect tube to inlet of drier, use lubricated O-ring seals on all fittings. Secure drier to condenser with wrap around bracket using 2) #10-32 X 1/2" screws & 2) #10-32 nuts.

3) Attach condenser inlet & drier outlet tubes as shown in photo 12, use lubricated O-ring seals on all fittings

4) Install tube support bracket as shown in photo 13 using 2) #10 X 1/2 hex head sheet metal screws.

*Tip: pre-drill holes for hex head mounting screws.*

## A/C HOSE INSTALLATION

**NOTE:** Hose Clamps should not be used with R-134A Refrigerant, a bubble style crimper is recommended. Even though hose clamps are acceptable for use with R-12 refrigerant, we recommend all A/C fittings be crimped.

For a custom appearance, hoses may be cut and assembled to length. We will crimp these at no charge, or most A/C shops or auto supply stores can also crimp the a/c hoses for a modest fee.

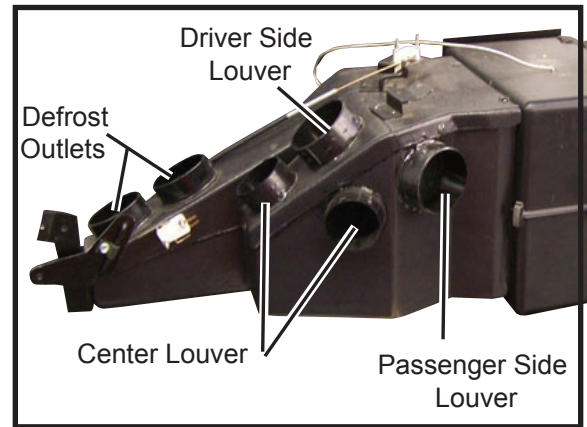

Photo 10 - Unit Outlet



Photo 11 - Mount Condenser

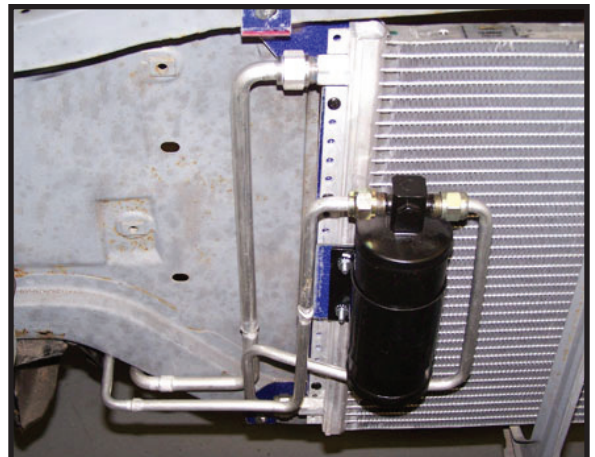

Photo 12 - Drier & Tubes



Photo 13 - Tube Support Bracket

**CAUTIONS:** [a] Use refrigerant oil to lubricate all O-rings on all hose fittings and connections. [b] Protective caps and plugs should not be removed until refrigerant hoses are ready to be connected. [c] O-Ring fittings should be tight, although excessive over tightening will crush O-ring seal. [d] Avoid sharp bends when installing hose. Hoses should not be too close to the compressor clutch, or touch hot or moving parts of the engine. [e] Slide necessary grommets on hose before routing thru fire wall and radiator cowling. Grommets will help prevent cutting hoses on sharp metal edges.

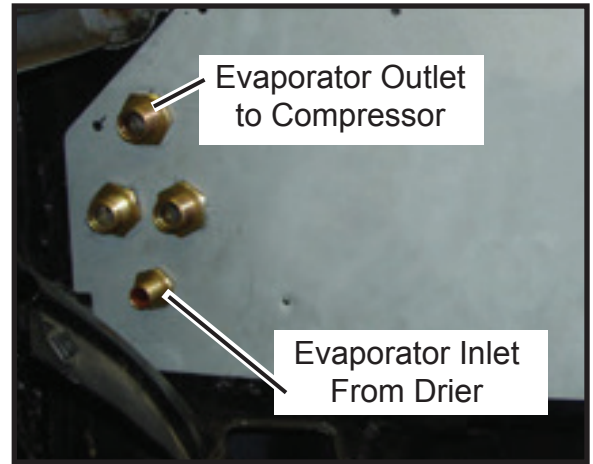

Photo 14 - A/C Fitting Locations

Refer to Diagrams #1 & #2 for the Following Steps 1-5.

1) The # 8 (13/32") discharge hose routes from the outlet of the compressor to the condenser inlet tube. Use lubricated # 8 O-rings with a 7/8" and 3/4" backup wrench to secure fittings. Tip: If the compressor is on the passenger side, we recommend first routing back toward the fire wall then looped forward to the inlet of the condenser. This allows for engine torque and vibration without damaging A/C hoses or fittings.

2) The # 10 (1/2") suction hose routes from the inlet of the compressor to the outlet of the evaporator. Use lubricated # 10 O-rings with a 1" and a 7/8" backup wrench to secure fittings. Tip: Likewise, this hose may be routed forward and looped back to the outlet of the evaporator. Using a pull tie where this meets the discharge hose in the center makes for a clean installation.

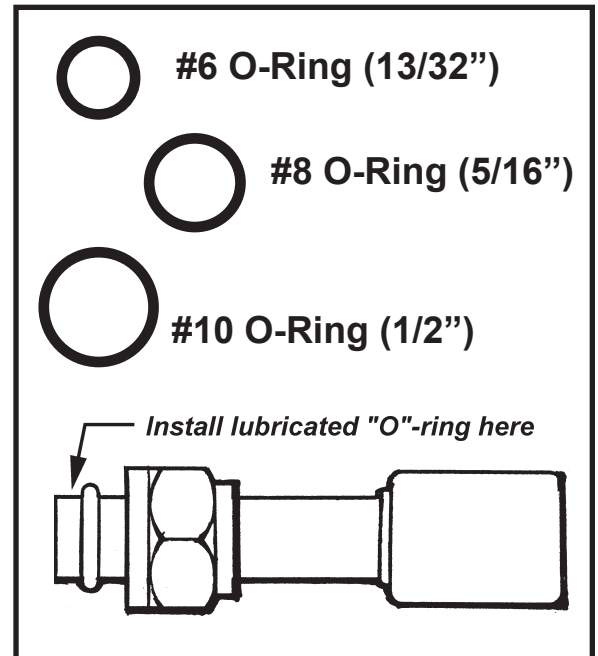

Diagram #2 - O-Ring Seals

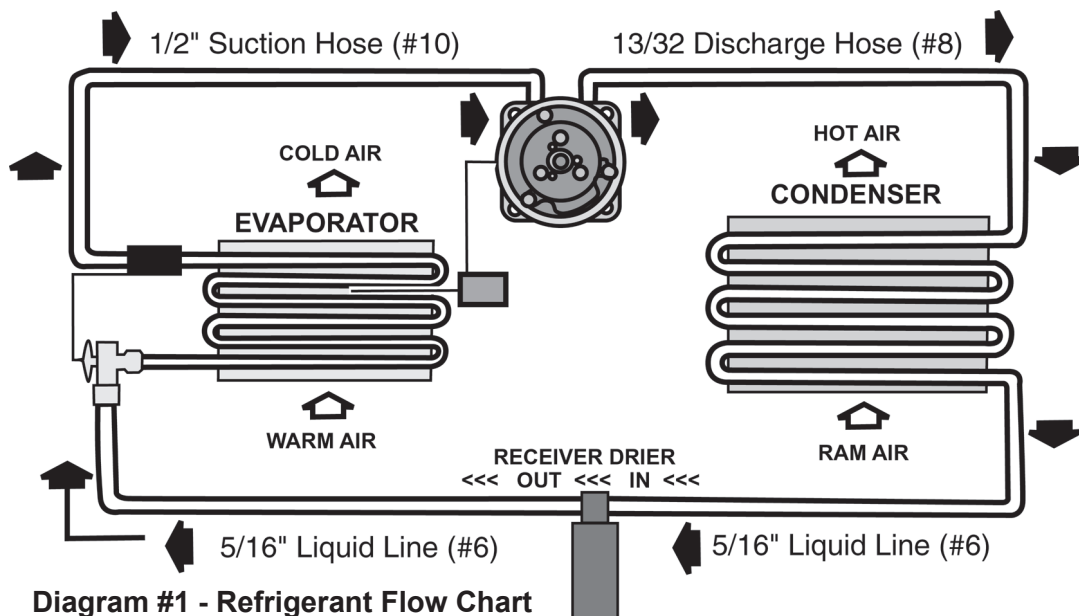

Diagram #1 - Refrigerant Flow Chart

3) Route a section of the #6 (5/16") hose from the Drier outlet tube to the inlet fitting on fire wall plate. Use lubricated # 6 O-rings with a 3/4" and a 5/8" backup wrench to secure fittings.

6) Install wrap-around hose clamps or pull-ties as necessary to secure all hoses away from sharp edges, moving parts and exhaust manifold or headers to avoid damage to hoses.

## INSTALL COMPRESSOR SAFETY SWITCH

All complete A/C Systems from Old Air Products include a binary safety pressure switch (24-0102). If installing optional trinary switch (24-0103) to operate electric condenser fans follow instructions included with trinary switch and skip to the heater valve installation section.

1) To install binary safety switch on drier remove hexagon shaped plug on the side near the top, insert binary safety switch using lubricated O-ring seal.

2) Place electrical plug on switch and connect one wire to the green wire coming through fire wall from the thermostat. The second wire will connect to the compressor clutch. We recommend waiting until the system is ready for the refrigerant charge before making this connection to the compressor to avoid compressor damage.

**CAUTION:** Make sure the terminals of the switch are inserted into the connectors, not between the rubber boot and connectors.

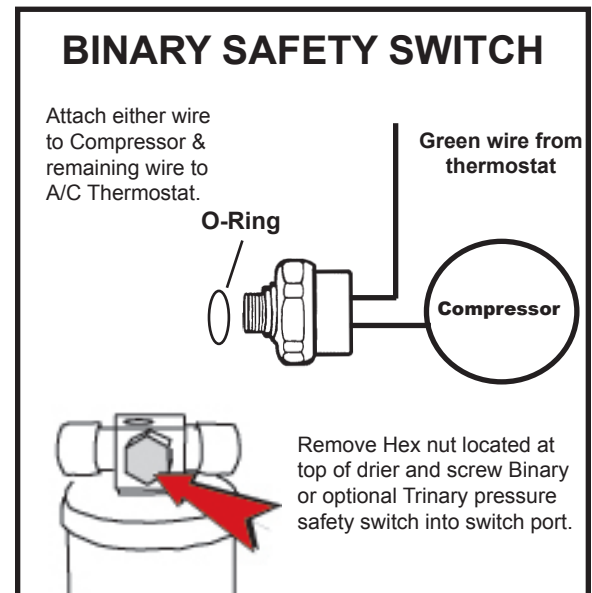

## HEATER HOSE AND VALVE INSTALLATION

NOTE: Vehicles with 3/4" heater hose will require a 5/8" heater hose nipple available from your local auto supply.

1) Route a section of heater hose from the engine heater outlet (usually on the intake manifold) to the heater inlet fitting (bottom tube) on the unit.

2) Route a second section of heater hose from the heater outlet fitting (top tube) on the unit to the heater return fitting on the engine (usually on the water pump).

3) Choose a convenient location in heater hose, Align the flow direction arrow and install 1 heater valve in each heater hose.

5) Install vacuum hose as per diagram 3

6) Fill radiator with antifreeze for a minimum protection of -10 degrees Fahrenheit.

## FREON SERVICE

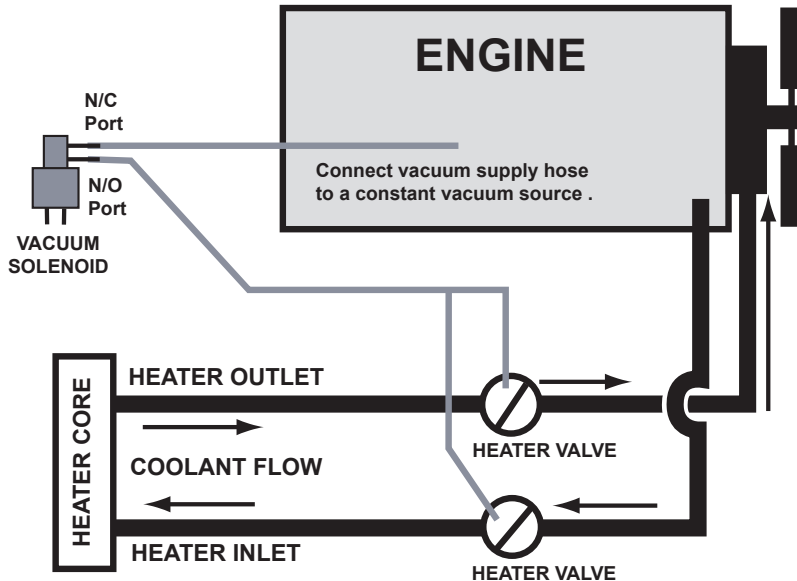

Diagram 3 - Heater Hose Flow

**INSTALLATION TIP:** Many high performance engines with larger camshafts will not produce a constant amount of vacuum during hard acceleration or similar situations. Installing a Vacuum Storage Canister (Old Air Products #23-7330) will help to maintain a constant vacuum for proper operation of the heater valves.

# Caution

This is not a blend system. The heater valve should not be opened while operating the air conditioning. You must maintain adequate antifreeze in the cooling system for -10 degrees Fahrenheit.

The heater valves must be opened to allow antifreeze to flow into the heater core before operating the A/C system so it will not freeze and rupture the heater core.

Neglect of these cautions will damage your system and Void Manufacturers Warranty.

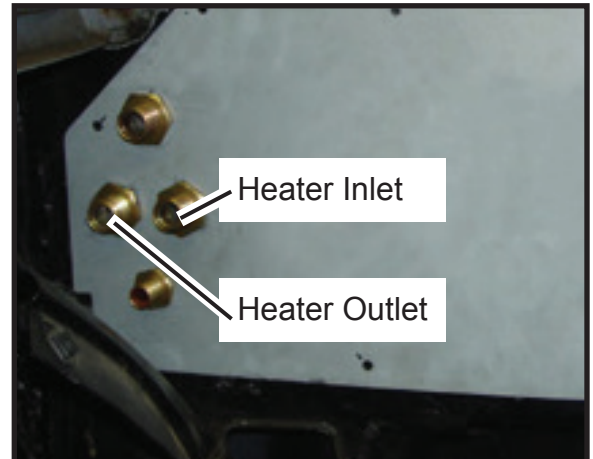

Photo 15 - Heater Fitting Locations

1) This system should be serviced/charged by a certified technician and requires a minimal vacuum pump evacuation of 45 minutes.

NOTE: When charging the system it will be necessary to put in about 12 to 18 ounces of refrigerant before the pressure safety switch will engage the compressor clutch.

2) R-12 Systems will require 30 to 36 ounces of Freon. This is only a guide line, and the sight glass (under the dimple area) on top of the drier should be monitored. The exact charge will be relevant to the length of hose, compressor capacity, and size of condenser.

2) 134-A Systems will require 28 to 32 ounces. An exact charge with 134-A is more critical for maximum performance than that of R-12. The exact charge will be relevant to the length of hose, compressor capacity, and size of condenser. We recommend adding a partial charge, and monitor temperature at vents while slowly adding remaining charge, while testing for point of maximum performance.

NOTE: This should be done with the doors shut, windows closed, convertible top up, fan on high blower, and an electric fan in front of radiator. If excessive high pressure exists adding an electric condenser fan is recommended if space permits.

3) Test all A/C connections for leaks.

4) Place a copy of these installation instructions in glove box for future reference.

Thank You for choosing  
an Old Air Products  
System for your Classic  
car or truck.

We appreciate letters of  
response and photos of  
you car or truck.



Regards,  
The Staff,  
Old Air Products



# SYSTEM OPERATION

**For A/C or Heater ON:** Move Fan switch (Left Lever) to desired fan speed.

**A/C MODE:** Move Temperature lever (Center) all the way to the top or COLD position. This will engage compressor & direct airflow to dash louvers.

**HEAT MODE:** Move Temperature lever (Center) down, & place DEFROST lever (Right) at top or OFF position. This will disengage compressor and begin moving airflow to floor outlet.

**DEFROST / FLOOR AIR:** Move Temperature lever (Center) to HOT position, & move DEFROST lever to direct airflow from floor to defrost outlets. NOTE: For dehumidified defrost place DEFROST lever all the way down in DEF position to engage compressor.

**A/C & HEATER SYSTEM OFF:** Move blower switch lever to OFF position.

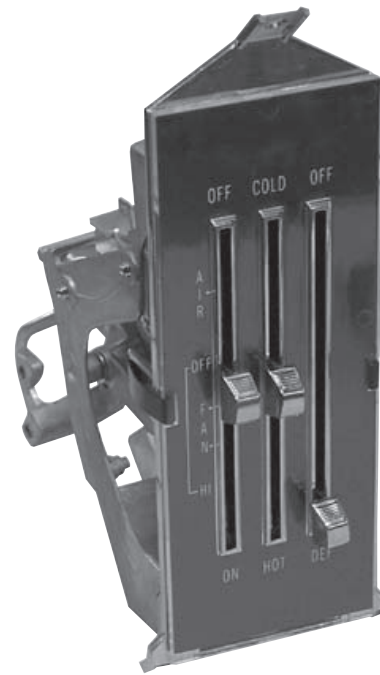

1969 Camaro - Heater Control

## Wiring Diagram CAP-3369

