

Installation Manual

1969 Firebird

DOCUMENT #1-2094

©2018 ClassicAutoAir / 03.18





Congratulations...

**You have just purchased the highest quality, best performing
A/C system ever designed for your Firebird.**

To obtain the high level of performance and dependability our systems are known for, please pay close attention to the following instructions. Our installation steps and procedures are derived from a long history of research and development and the combined experience achieved thru thousands of successful installations (and feedback from customers like you). Please remember that our #1 goal is that you'll have a successful installation and a system that performs at a very high level for many years to come.

Before starting, read the instructions carefully, from beginning to end, and follow the proper sequence. On the next page you'll find a safety and general checklist that you should read before starting your installation.

Again, thank you from our entire staff.



Check List, Pre-Installation:

- Before beginning the installation check the shipping box for the correct components. YOUR BOXED UNIT INCLUDES A LIST OF MAJOR COMPONENTS AND A LIST OF BAGGED PARTS. We have a 5 stage check process to make sure you have everything you'll need.
- If your vehicle has been or is being modified, some procedures will need to be adjusted to fit your particular application.**
- A basic cleaning of the engine compartment and interior before beginning will make things go more smoothly.
- Check condition of engine mounts. Excessive engine movement can damage hoses to A/C and/or heater.
- Before starting, check vehicle interior electrical functions (interior lights, radio, horn, etc). Make a note of anything that does not work as it's supposed to. During the installation you might find the opportunity to repair or upgrade non-working or out of date components. When you're ready to start the installation, **DISCONNECT THE BATTERY FIRST.**
- Drain the radiator. Retain the coolant and reuse, or dispose of properly.
- SAFETY FIRST: Wear eye protection while drilling/cutting, deburr sharp edges, and never get in a hurry or force a part.
- Tools: Your installation only requires the basic tools everyone has in their garage, nothing exotic or specific to A/C or Heat equipment.

Procedures, During Installation:

- Fittings: Use one or two drops of mineral oil (supplied with your kit) on ALL rubber o-rings, threads and rear of bump for o-ring where female nut rides. Do not use thread tape or sealants.
- Measure twice (or more), cut once
- Should you have any technical questions, or feel you have defective components (or missing items), call us immediately, we will be glad to assist you. Our toll-free number is listed on every page, we're here to help!**

YOU CAN NOW BEGIN THE INSTALLATION...

A Basic Overview of Automotive A/C....

- 1 Evaporator with Blower Fan** In order to remove the heat from the air in the vehicle, the A/C evaporator allows the refrigerant to absorb the heat from the air passing over it. The blower fan moves cool air out into the car interior.
- 2 Compressor** The compressor pumps and circulates the refrigerant through the system.
- 3 Condenser** The condenser is a heat exchanger mounted at the front of the vehicle. Heat drawn out of the interior of the car is expelled here.
- 4 Receiver/Drier** The drier not only dries refrigerant, it also filters the refrigerant and stores it under certain operating conditions.
- 5 High Pressure Switch** A pressure switch is used to shut down the system if high or low pressure is detected, basically it acts as a safety switch.

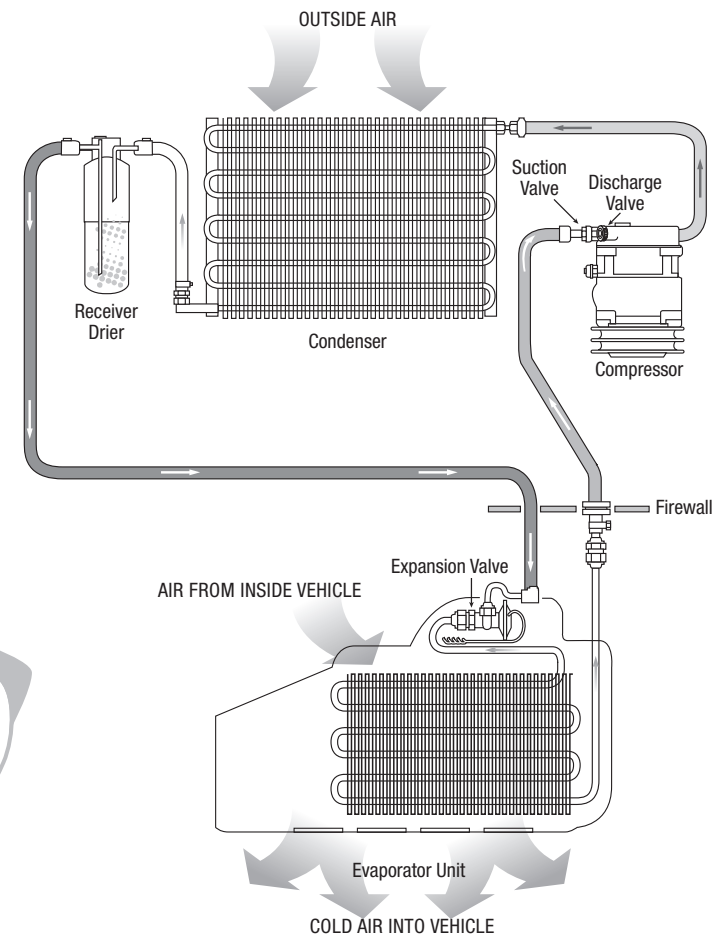
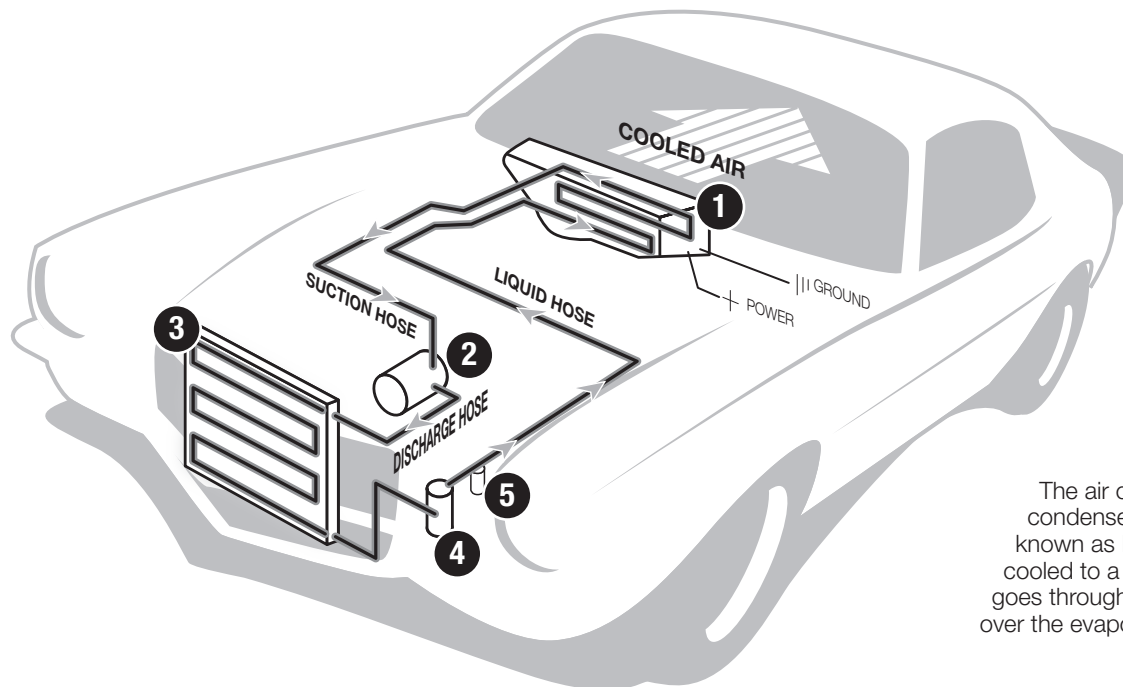

The air conditioning system in your car is comprised of a compressor, condenser, expansion valve, receiver/drier, and evaporator. Refrigerant (also known as Freon) is compressed in the compressor. In the condenser, gas is cooled to a liquid state and travels to the expansion valve. As the liquid refrigerant goes through the expansion valve it rapidly cools in the evaporator. A fan blows over the evaporator and cools the air that blows out your vents



Control & Operating Instructions



Your new **Perfect Fit-Elite** system offers complete comfort capabilities in virtually every driving condition. This includes temperature control in all of the modes. This system also provides the ability to blend the air between Face, Heat, and Defrost modes simultaneously. To illustrate the various ways you can adjust the airflow direction and temperature - we've provided these handy illustrations and chart to show exactly how you can adjust your **Perfect Fit-Elite** for maximum comfort...

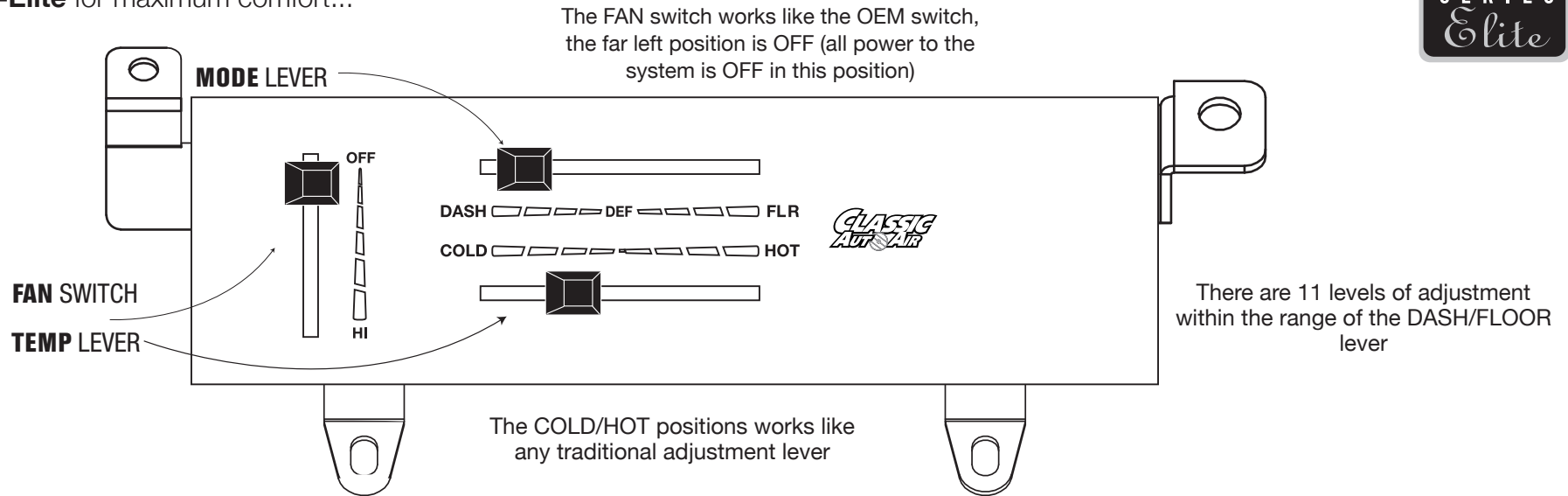

	DASH					DEF					FLOOR
Left Lever Position	1	2	3	4	5	6	7	8	9	10	11
Distribution	Face A/C 100%	Face A/C 80%	Face A/C 60%	Face A/C 40%	Face A/C 20%	Defrost 100%	Floor 20%	Floor 60%	Floor 40%	Floor 80%	Floor 100%
		Defrost 20%	Defrost 40%	Defrost 60%	Defrost 80%		Defrost 80%	Defrost 40%	Defrost 60%	Defrost 20%	
Compressor State	ON					ON					



Remove Glovebox, Console (optional) Radio and Bezel, and set them aside for reinstall later (see figure 1).

The removal of the Original Heater Assembly can be accomplished by disconnecting three control cables. One is attached to the Heat/Defrost door (see figure 2). One is attached to the Temperature door, and one is attached to the Vent / Heat door (see figure 3). Disconnect the electrical harness from the assembly. Also remove attachment screw located in front of the air inlet (see figure 4).



When retaining parts it's a good idea to store parts in a zip lock bag, labeled with info where the parts came from and what size/type of

tool is needed to reinstall. Cleaning the parts before you need to reinstall them is a good idea too.

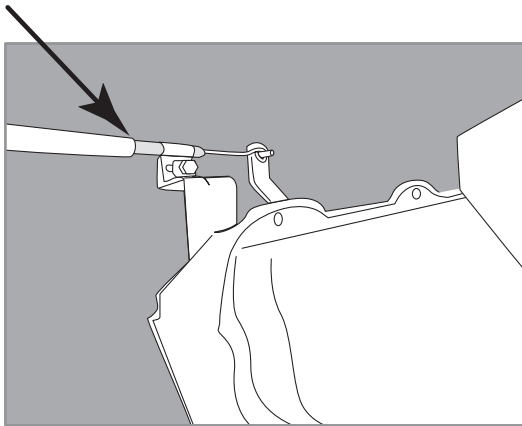
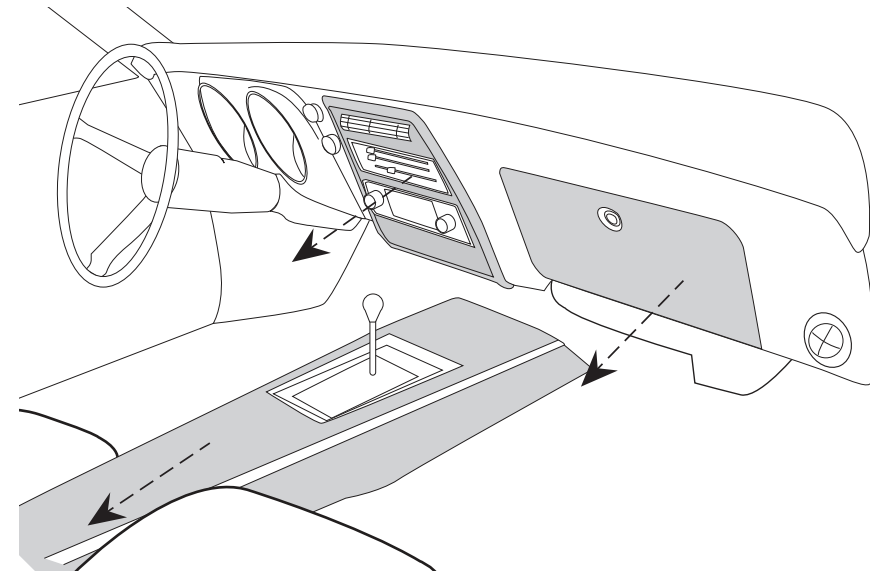

FIGURE 2

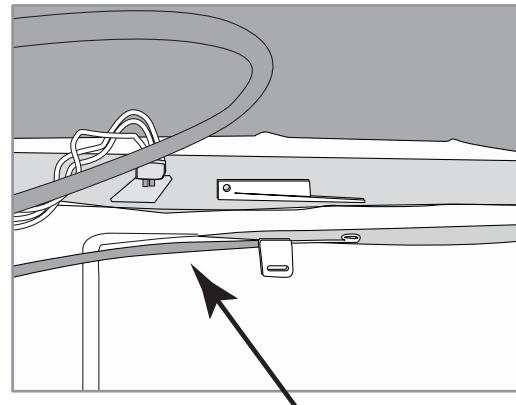

FIGURE 3

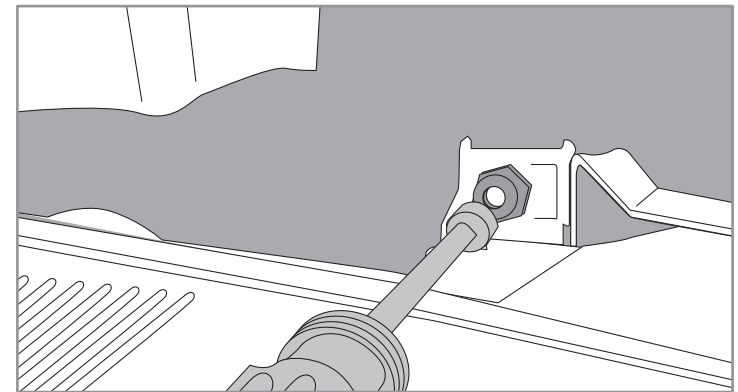

FIGURE 4

Disconnect the electrical harness at the resistor block (see Figure 5).

Remove the OEM control head, which is held in with two screws. Retain the OEM screws.

Set the control head aside (you'll need the bezel later).

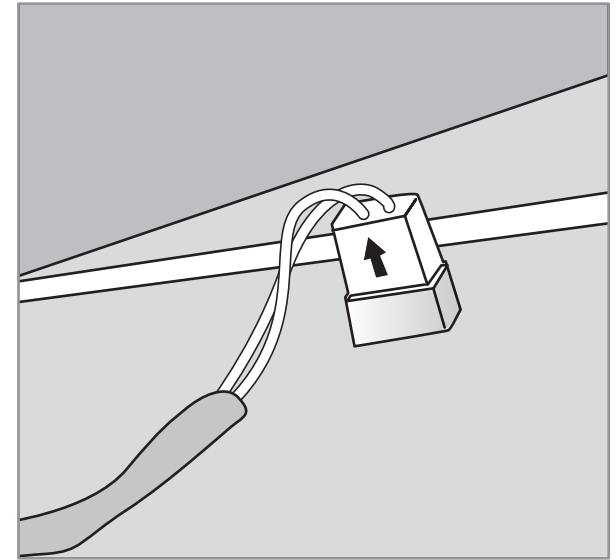
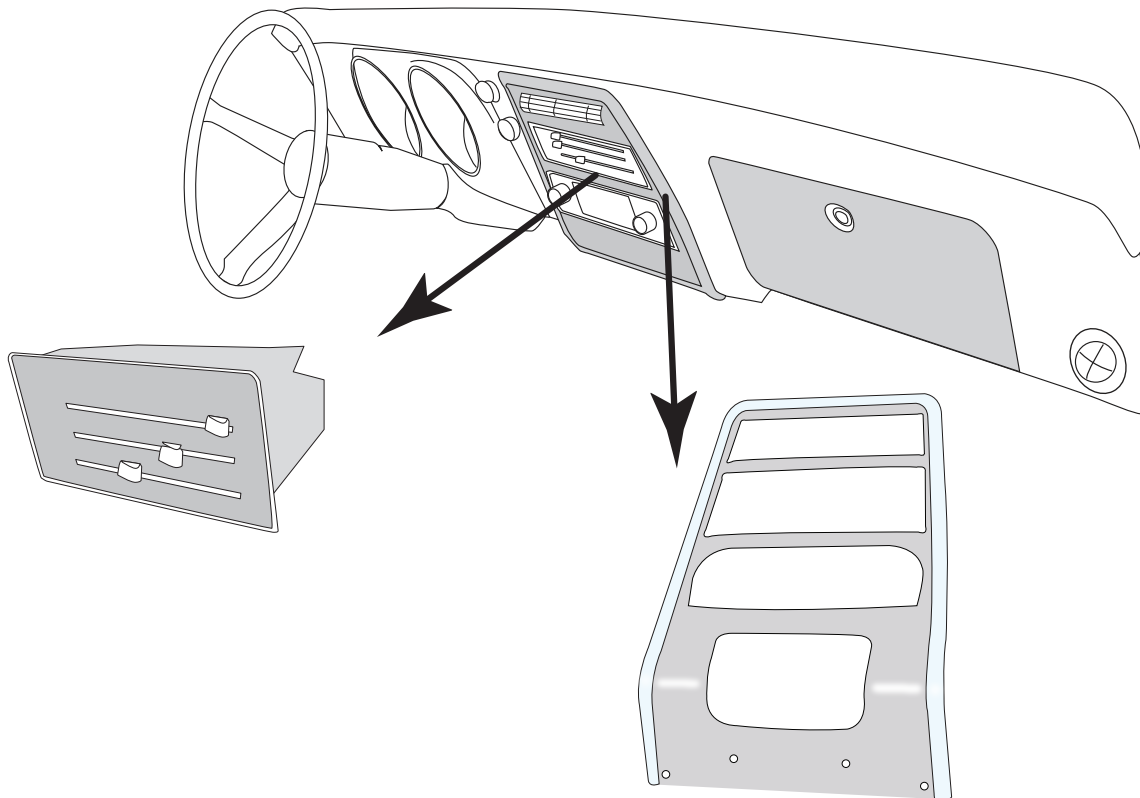

FIGURE 5

Moving to the engine compartment:

In order to remove your heater assembly it is necessary to remove the heater case housing first.

Located on the engine side of the firewall, remove seven (7) bolts around the perimeter of the heater case housing (see Figure 7). Remove the housing (Discard).

NOTE: To remove the two bolts at locations **1A** and **7B**, it may be necessary to lower the inner fender. Retain these screws.

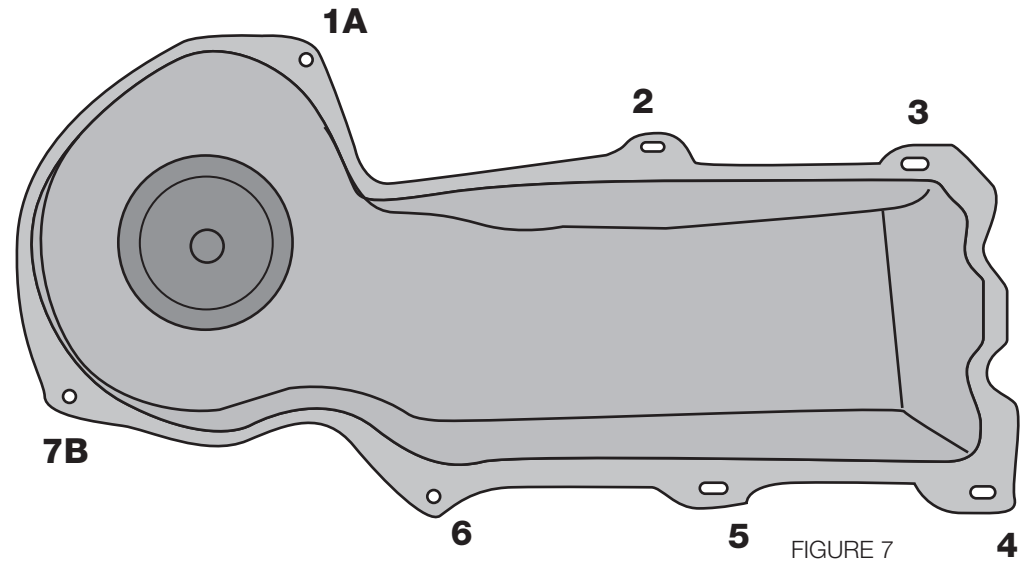

FIGURE 7

Drain coolant from radiator. Remove the heater hoses from heater coil and firewall (see Figure 8).

You will also cut a power lead to the blower motor. This will not be re-used.

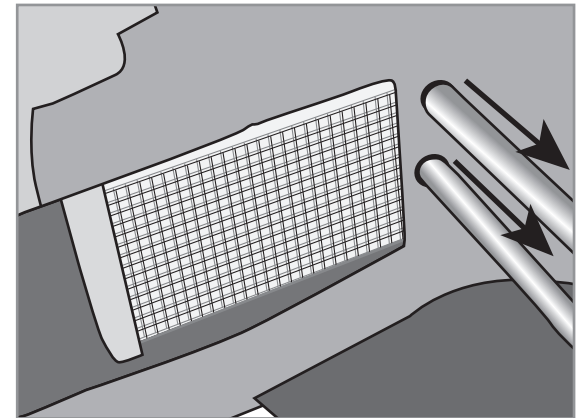
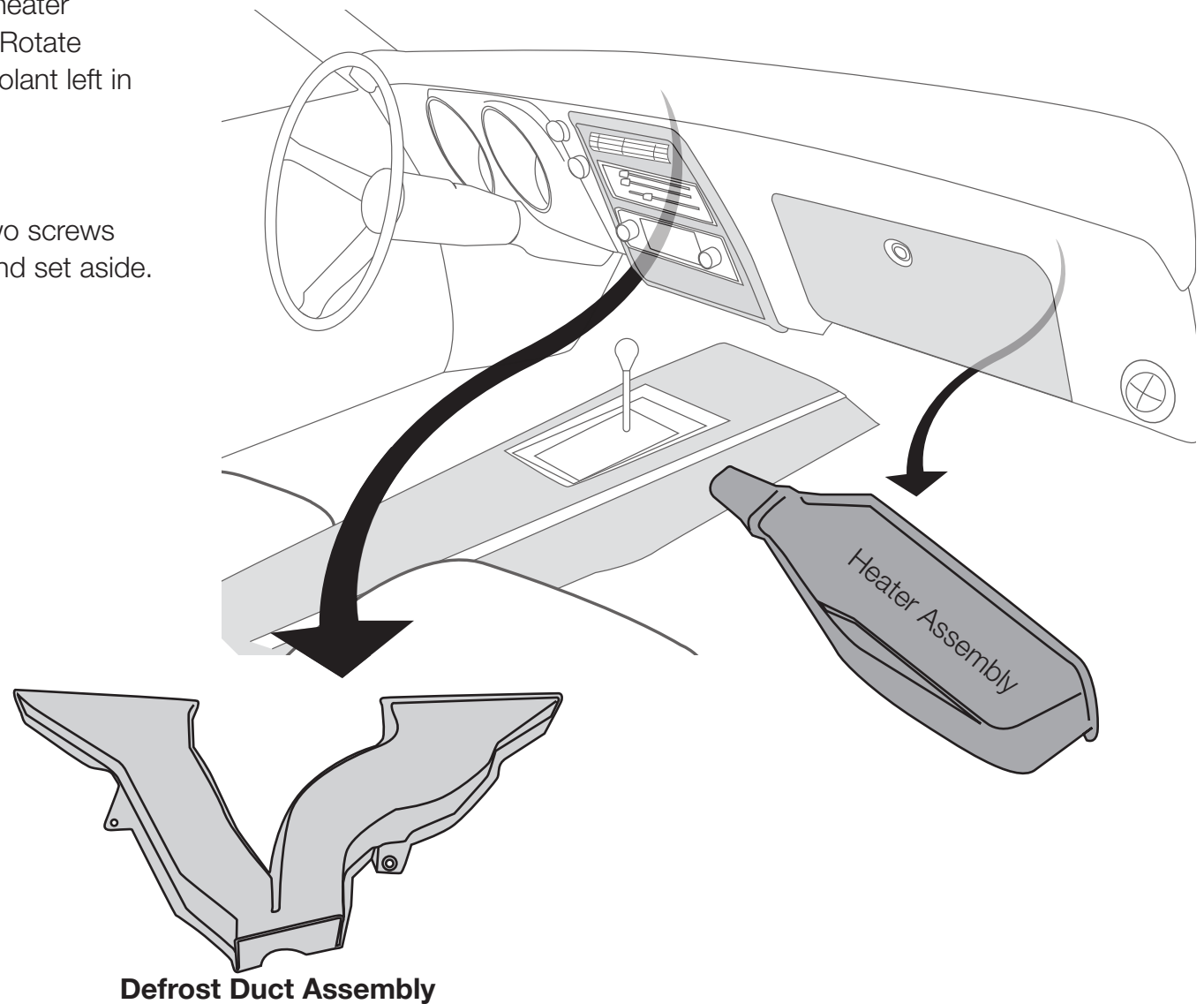

FIGURE 8

You should now be able to remove the heater assembly located behind the dash area. Rotate upward being careful not to drain any coolant left in the heater coil.

The OEM defrost duct is secured with two screws remove both screws from defrost duct and set aside.





THESE ARE THE PARTS YOU WILL FIND IN CONTROL BOX

You will use all of these parts and hardware during the next series of installation steps.

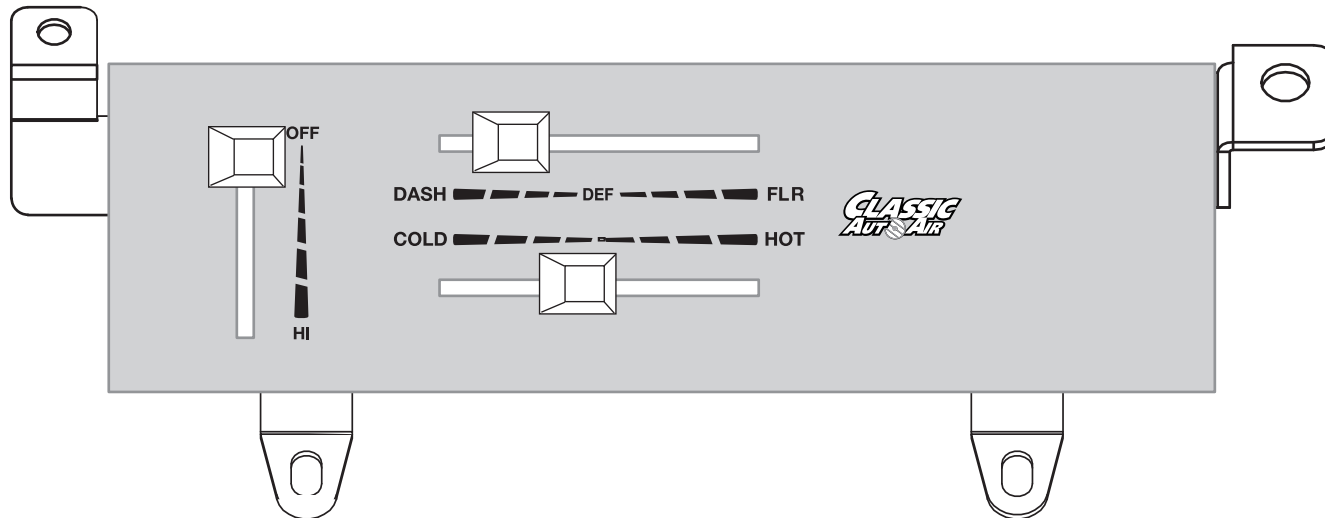

D.E.R. Controller
PN# 16-3093



THESE ARE THE PARTS YOU WILL FIND IN BAG KIT B

You will use all of these parts and hardware during the next series of installation steps.

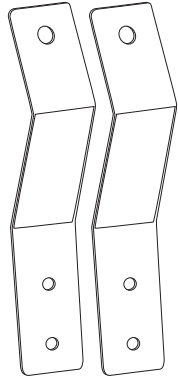

Evaporator Support Brackets
PN#0023-7

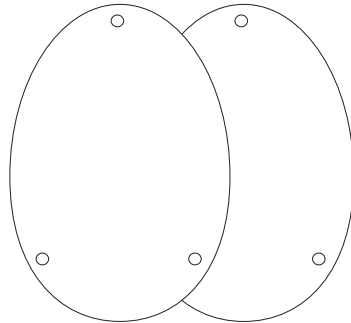

Two Air Inlet Block Offs
PN#0047-1

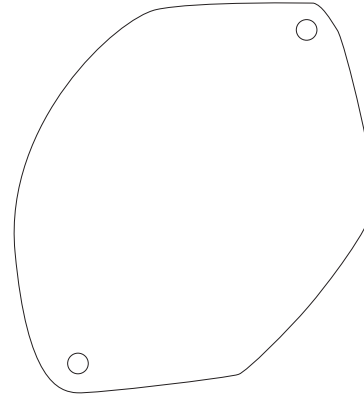

Fresh Air Inlet Block Off
PN#10-1048-2

Liquid Tube
PN#0034-9

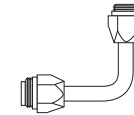

Suction Tube
PN#0034-10

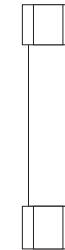

 #6 and #10 O-ring

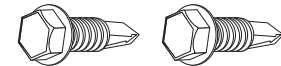

Two #10 - 16 x 3/4" Tek Screws

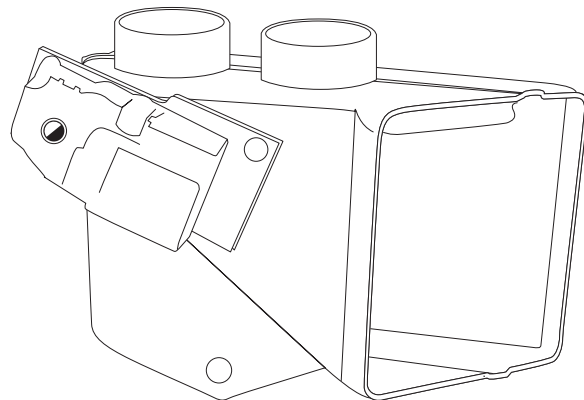

Defrost/Heat Duct Assembly
PN#2-2025-2



One Bulb Clamp

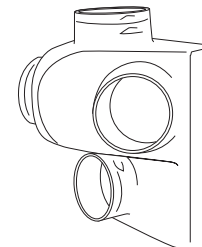

Face/Floor Assembly
PN#2-2025-1

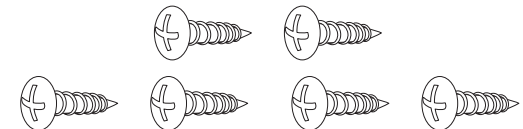

Six #10 - 10 x 5/8" Phillips Screws



One Male Spade Connector

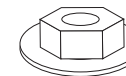

One Flange Nut

Illustrations NOT shown actual size

Within the engine compartment area, Install Fresh Air inlet block-off Pn# 10-1048-2 (from Bag Kit B) over the OEM fan opening using the OEM screws (A1 and B7).

If necessary, reinstall inner fender.

Remove evaporator unit from box and place on a work surface.

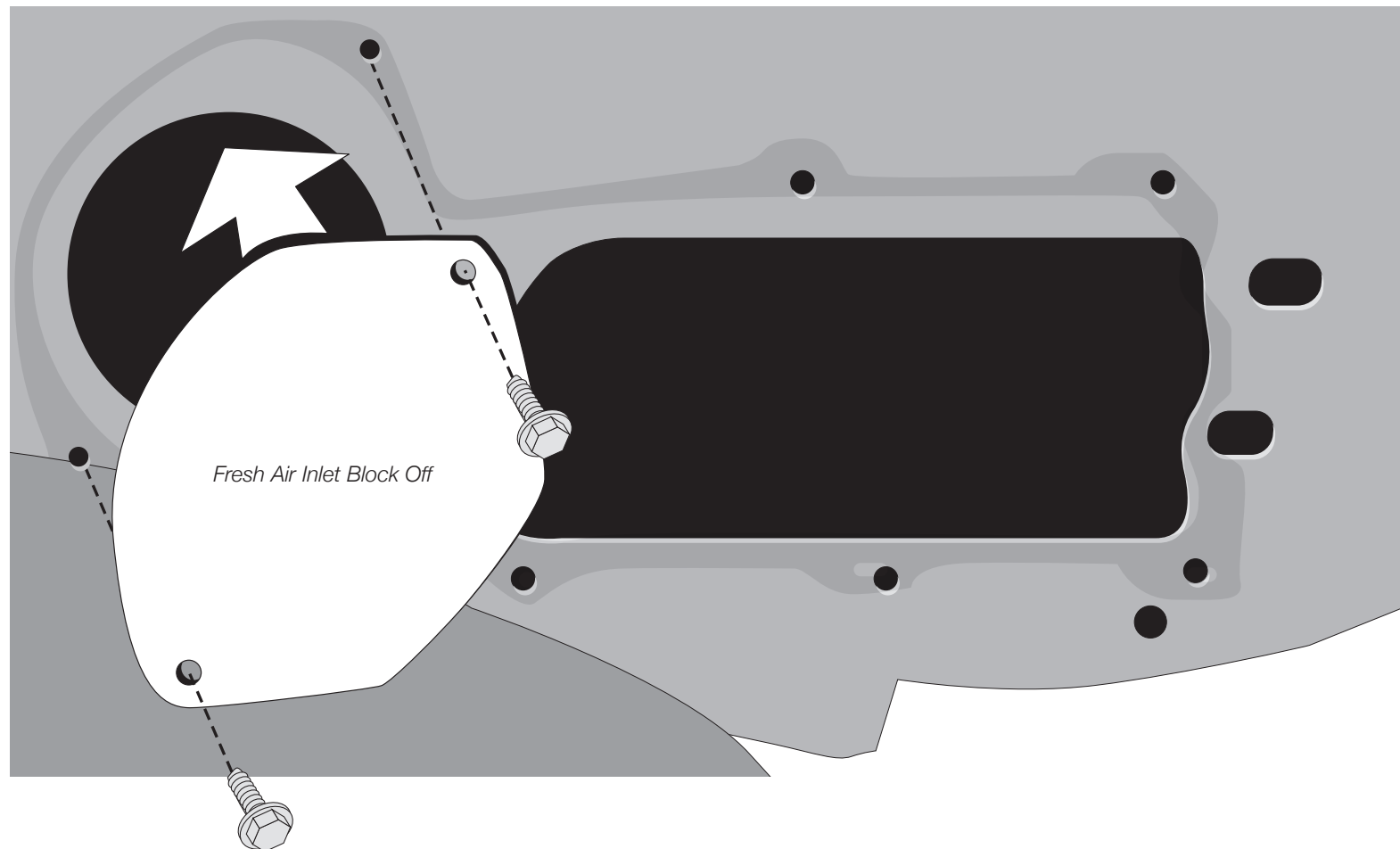

Familiarize yourself with the Evaporator



Take a minute to familiarize yourself with the evaporator unit:

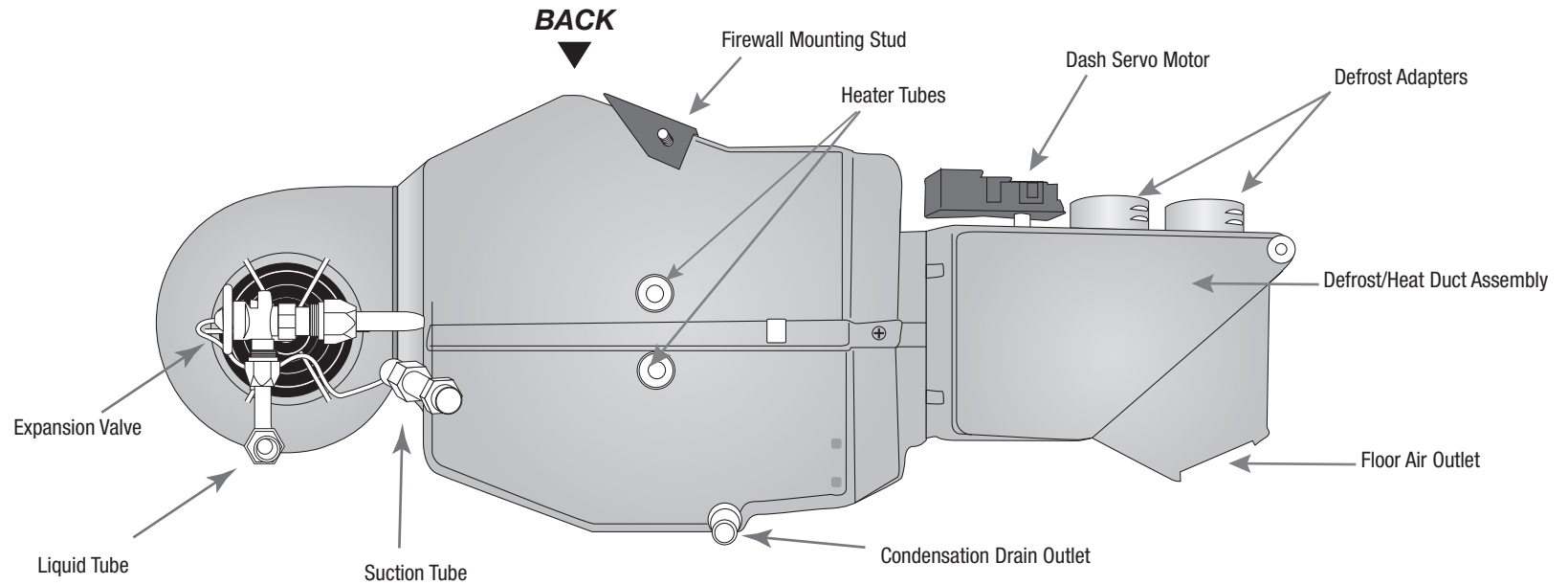
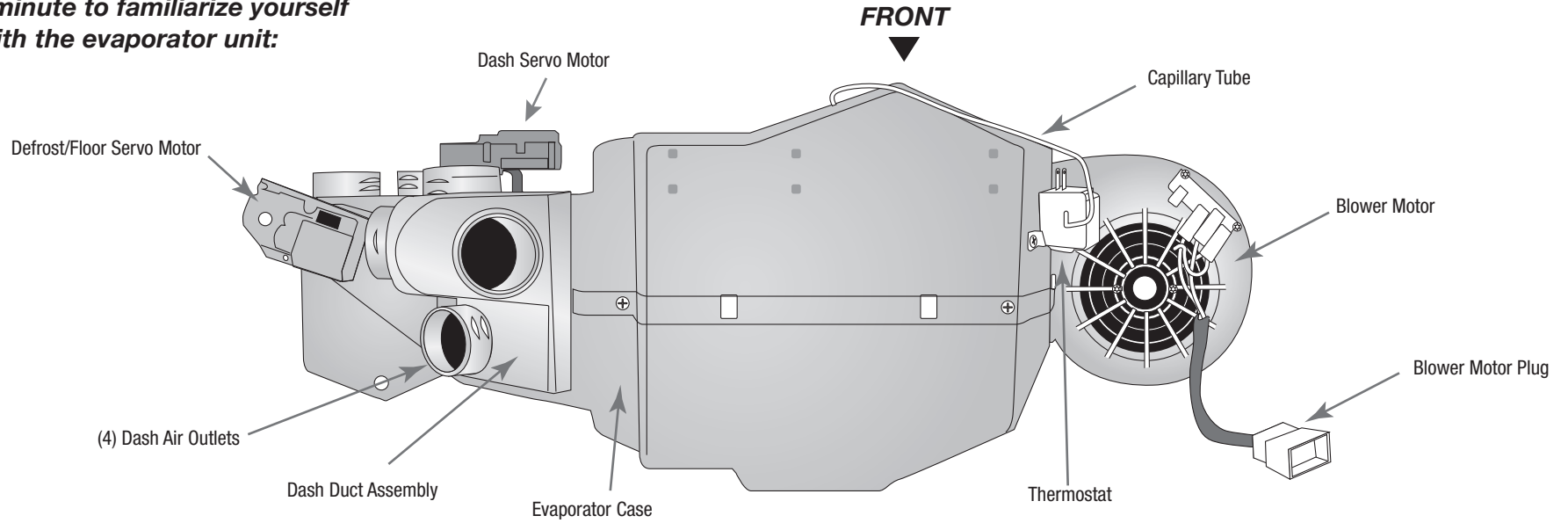

BENCH CALIBRATION & FUNCTION TESTING

• Items Needed for Bench Calibration

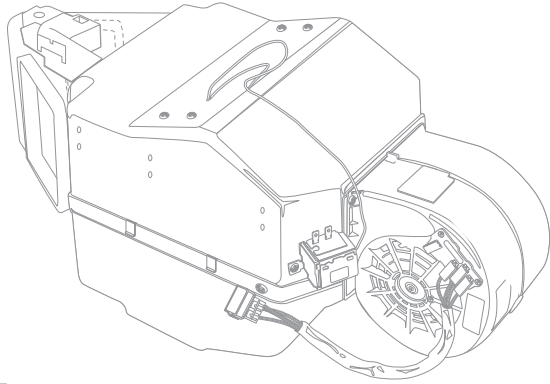

Locate Evaporator Unit from Main Box

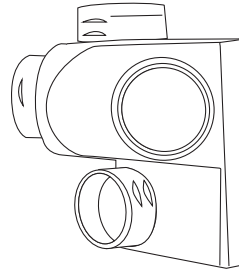

Locate Face Duct Assembly from Bag Kit B

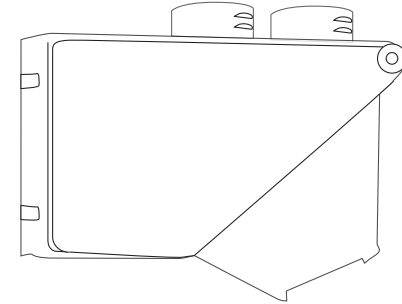

Locate Defrost/Heat Duct Assembly from Bag Kit B

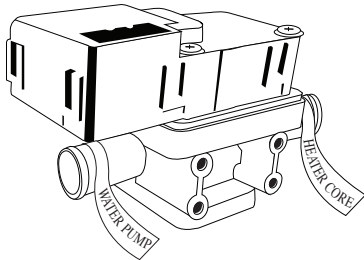

Locate electronic water valve from Bag Kit D

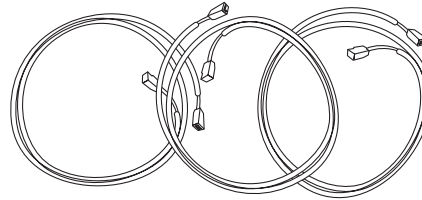

Locate Blue, Yellow, Orange wiring harness from Bag Kit C

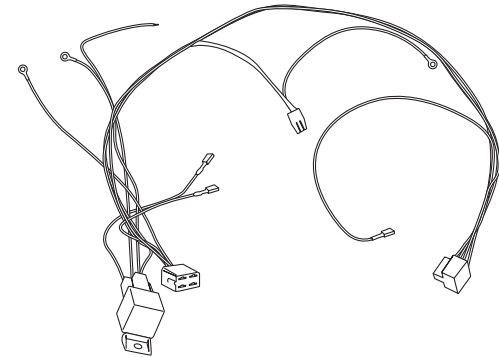

Locate main wiring harness from Bag Kit C

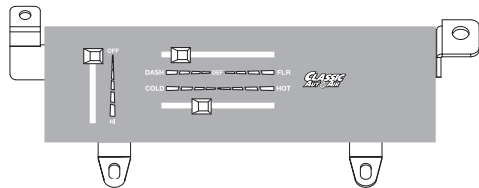

Locate the D.E.R. control in the CONTROL BOX

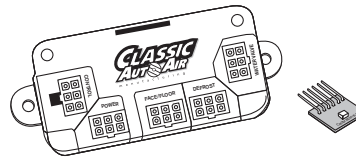

Locate ECU and Calibration Key from Bag Kit C

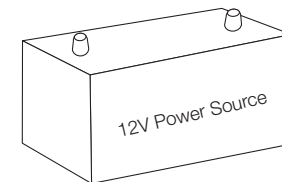

Acquire a 12V Battery (NOT a battery charger)

BENCH CALIBRATION & FUNCTION TESTING

• Install Duct Assemblies

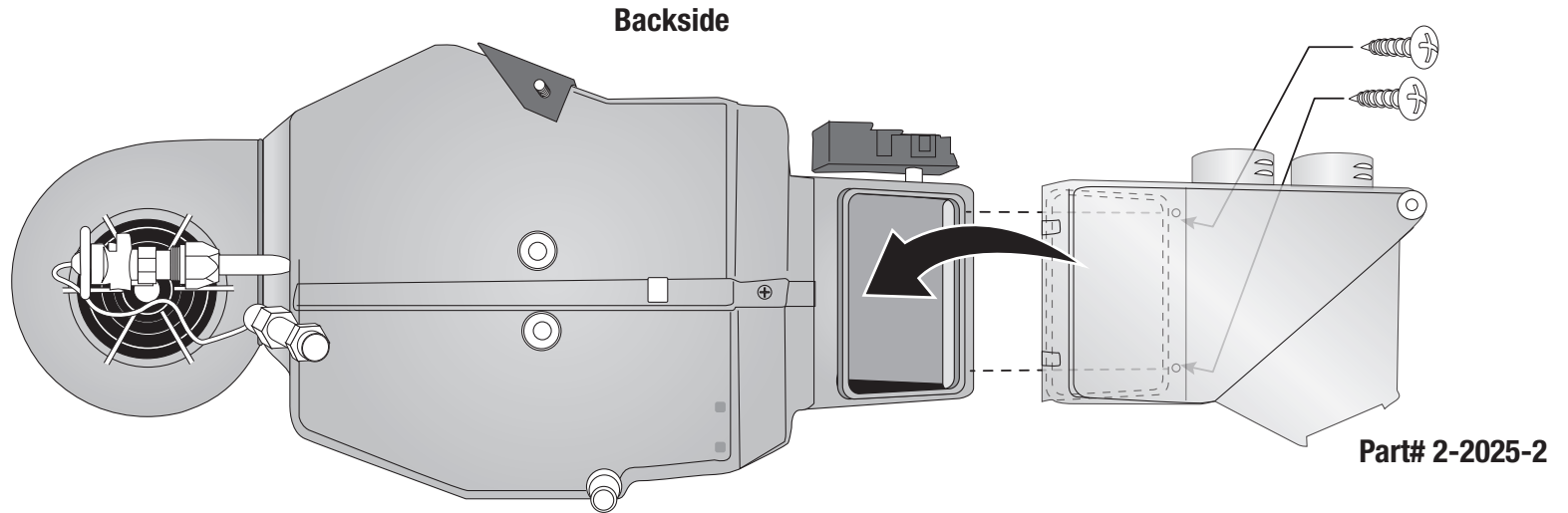

Push S-Clips over flange securing with two #10x5/8" screws, from back

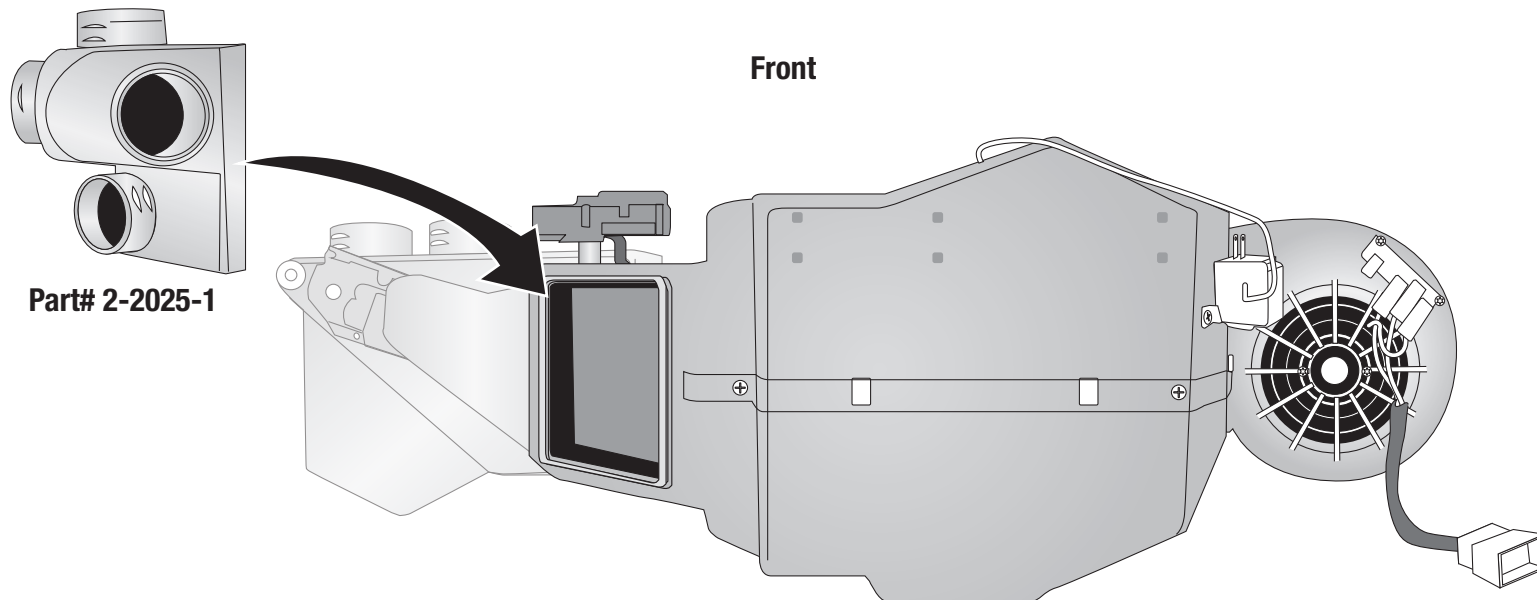

Attach to front outlet securing with pre-installed S-Clips

BENCH CALIBRATION & FUNCTION TESTING

• Wiring Preparation Steps 1 through 3

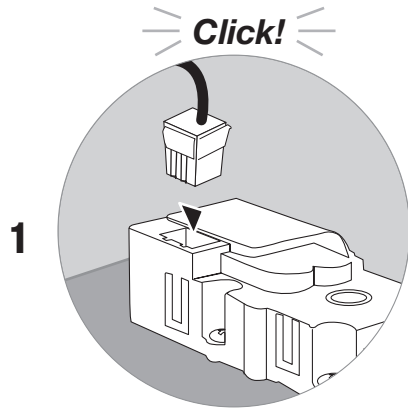

Connect Blue Harness into Defrost/Heat Servo Motor

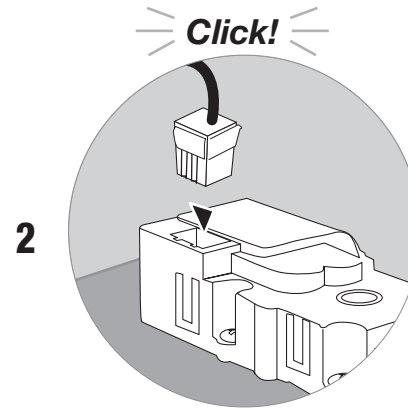

Connect Yellow Harness into Face/Floor Servo Motor

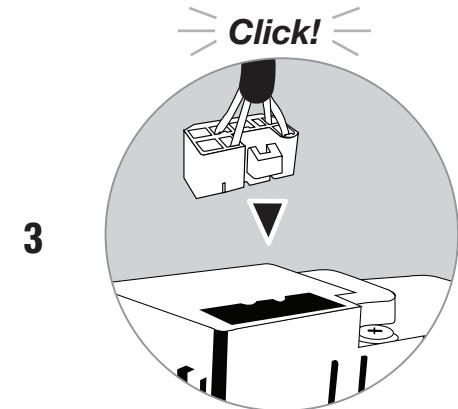

Connect Orange Harness into water valve

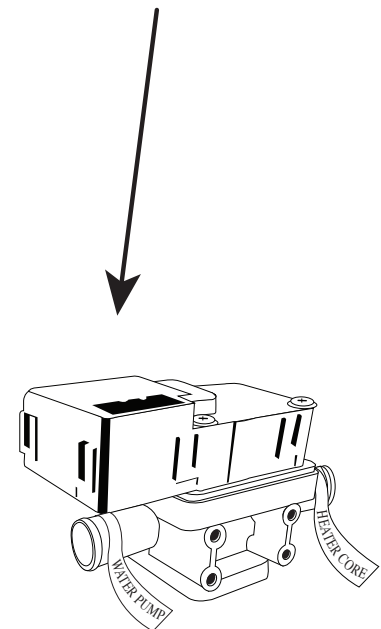
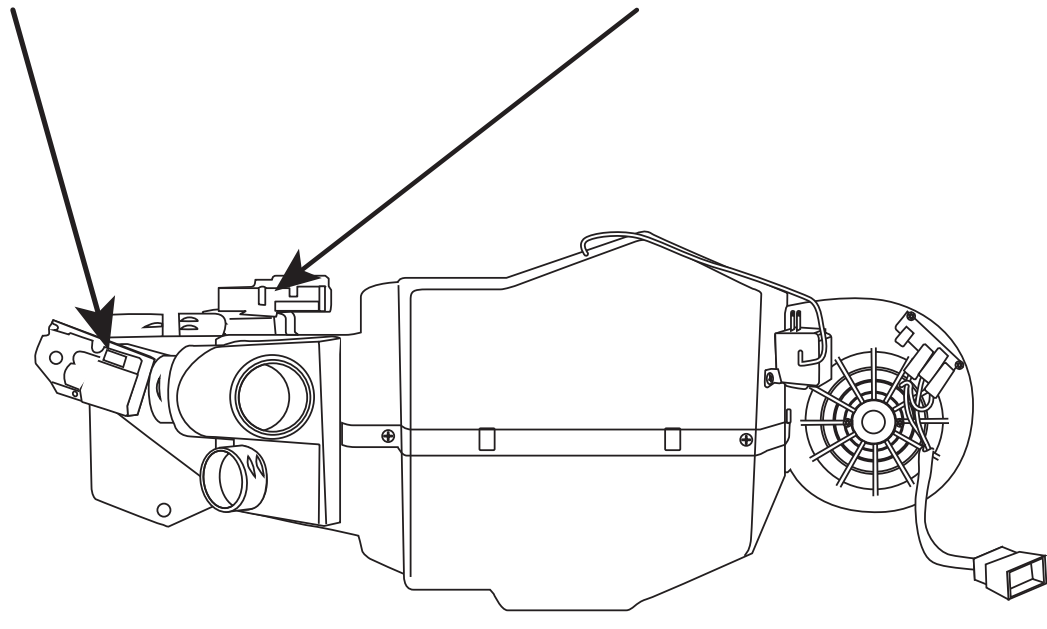

BENCH CALIBRATION & FUNCTION TESTING

• Wiring Preparation Steps 4 though 7

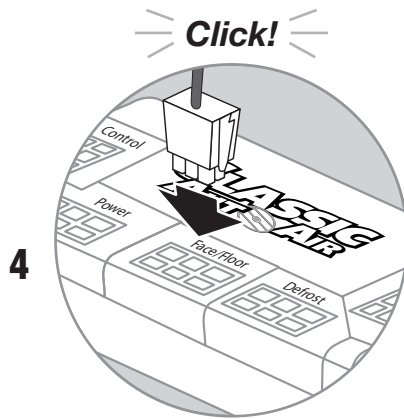

Connect Yellow Harness into Face/Floor Port on ECU

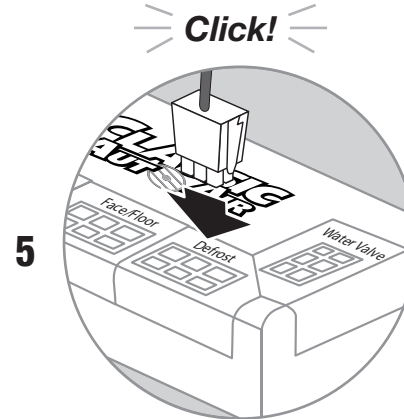

Connect Blue Harness into Defrost/Heat Port on ECU

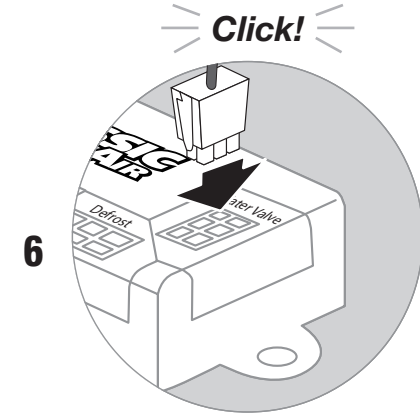

Connect Orange Harness into Water Valve Port on ECU

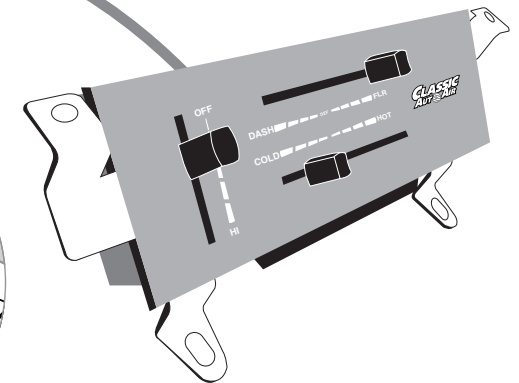
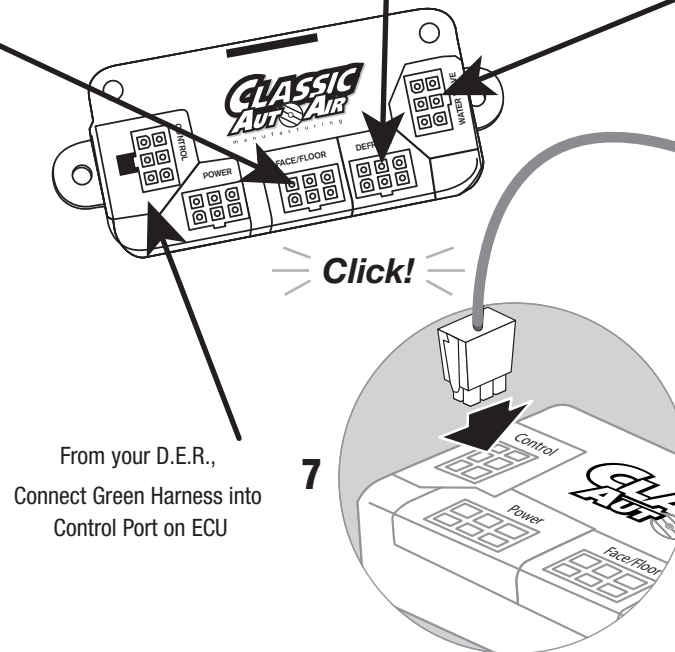

BENCH CALIBRATION & FUNCTION TESTING

• Wiring Preparation Steps 8 through 12

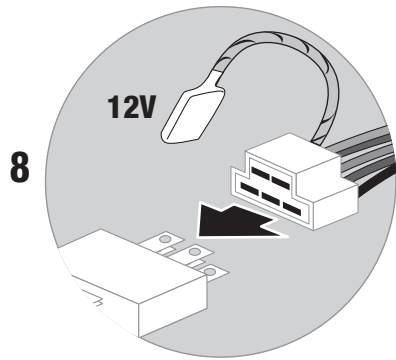

8

Connect corresponding Fan Switch harness to the Bower Switch on Controls
Connect Power lead to 12V.

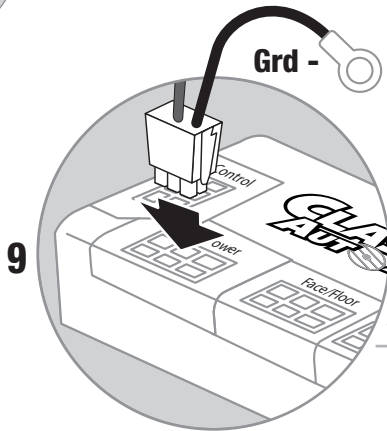

9

Connect red tagged power harness to POWER port on ECU.
Connect ground.

Click!

10

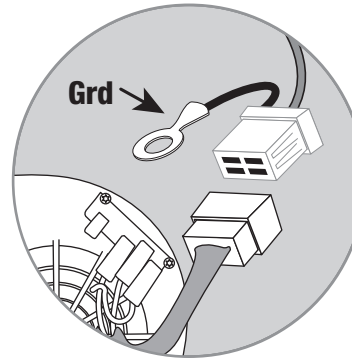

Connect corresponding fan motor harness.
Connect ground.

Click!

12

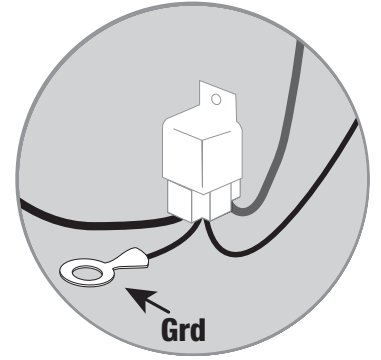

Connect ground.

11

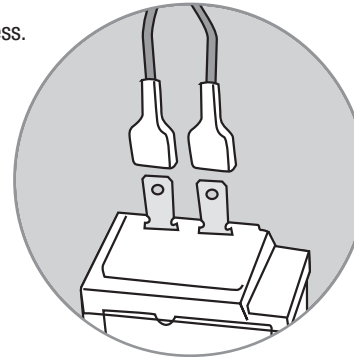

Connect both BLUE leads into thermostat
(either lead into either terminal)

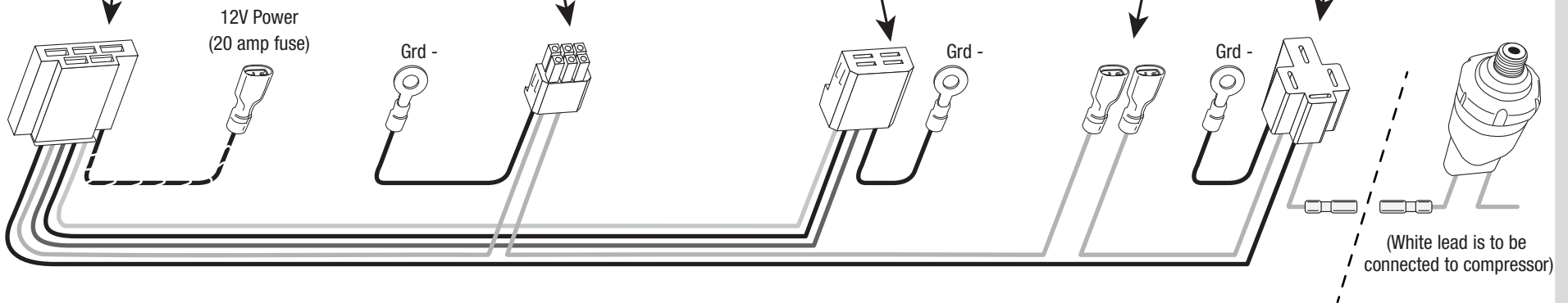

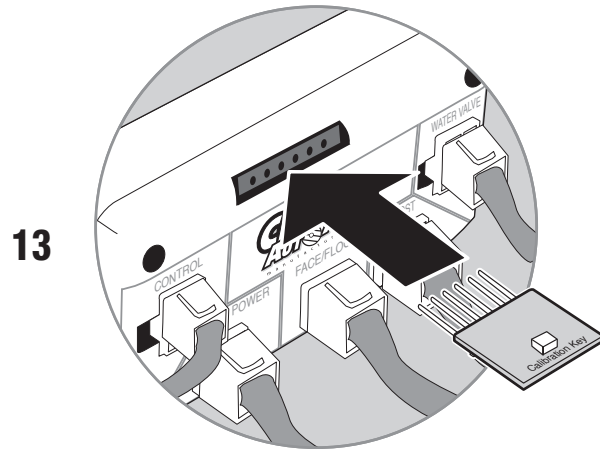

Insert Calibration Key as shown (LED up) into 6-pin connection in ECU

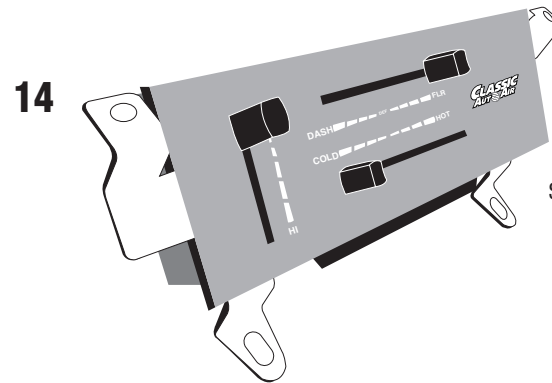

Start by positioning the D.E.R. knobs as shown:

- Fan: Off
- Mode: Floor
- Temp: Cold

15
Move Fan Knob to Center...

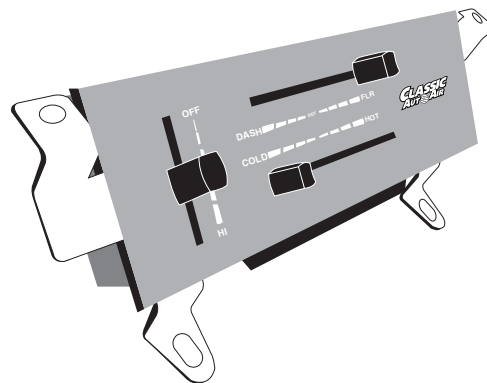

YOU WILL SEE...

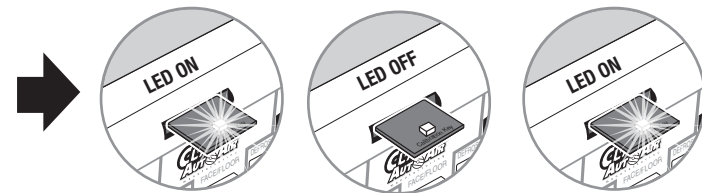

16

Move MODE knob to DASH
in one motion

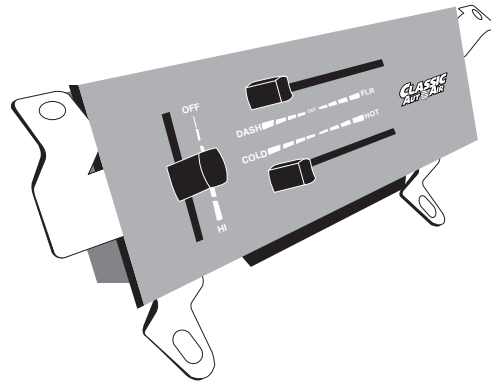

AFTER YOU MOVE THE KNOB YOU WILL SEE...

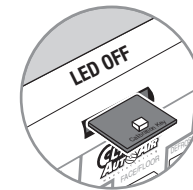

17

Move TEMP knob to HOT
in one motion

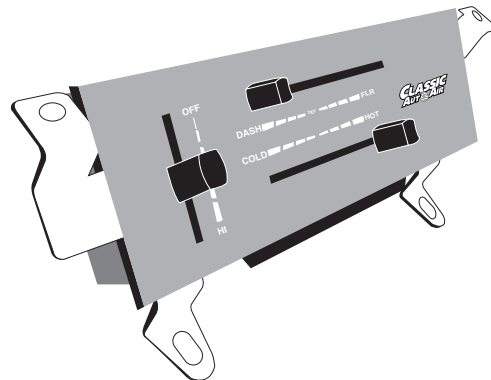

AFTER YOU MOVE THE KNOB YOU WILL SEE...

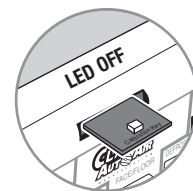

BENCH CALIBRATION & FUNCTION TESTING

• Calibration, Steps 18 thru 20

You will be able to hear the internal door(s) move back and forth and feel air coming out of the outlets

18

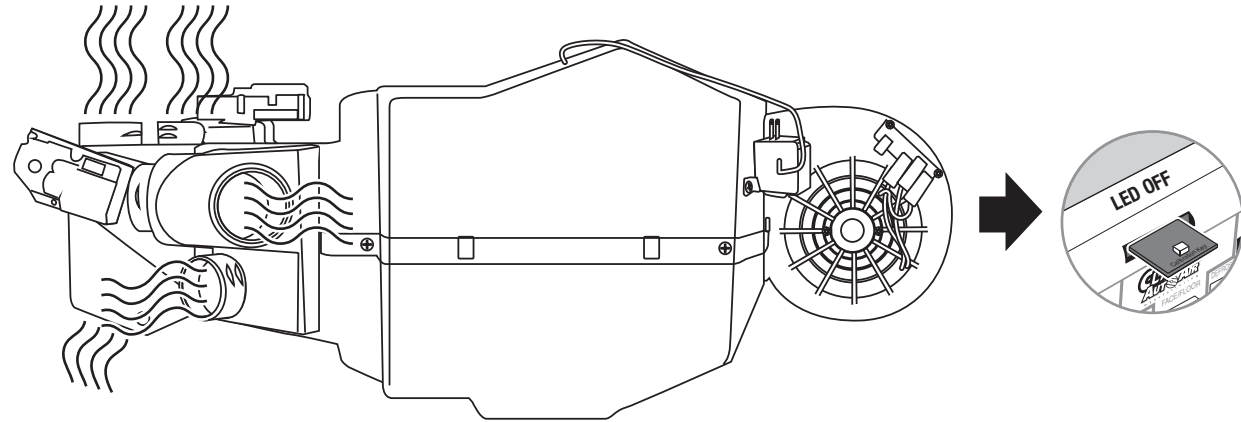

19 Move FAN knob to OFF

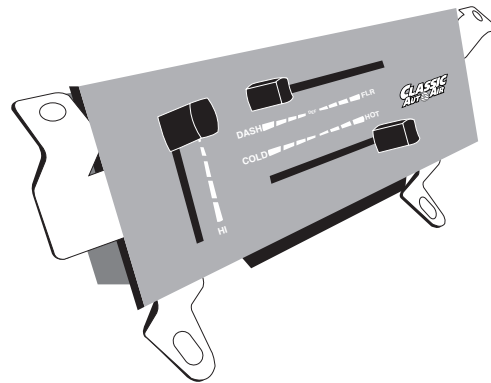

20

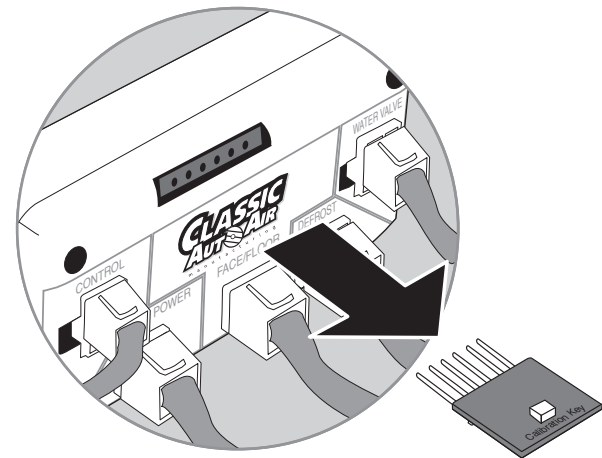

REMOVE CALIBRATION KEY FROM ECU AND STORE IN A SAFE PLACE

BENCH CALIBRATION & FUNCTION TESTING

• Function Test, Steps 1 thru 3

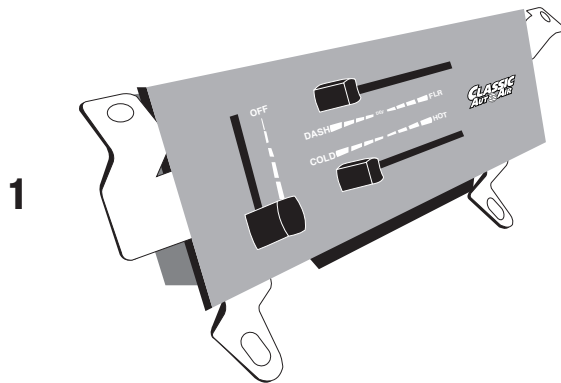

Move FAN knob to HIGH
Move MODE knob to DASH
Move TEMP knob to COLD

AIR OUT OF DASH VENTS

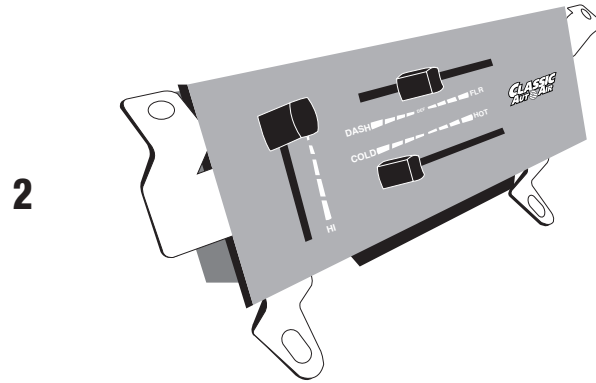
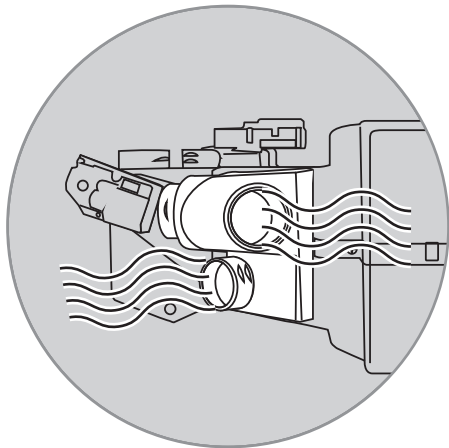

Move MODE knob to DEF

AIR OUT OF DEFROST VENTS

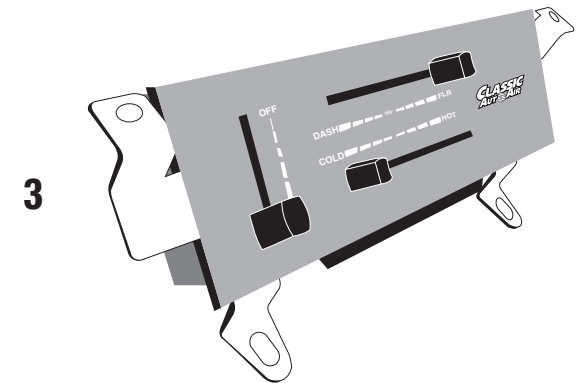
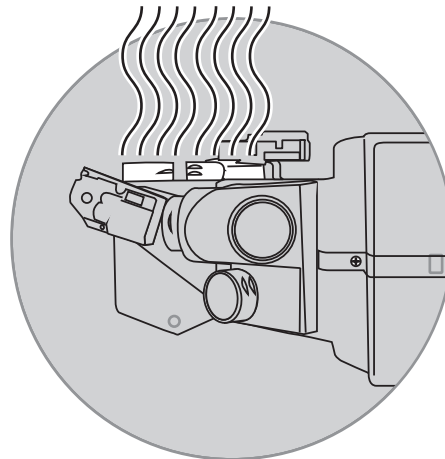

Move MODE knob to FLOOR

AIR OUT OF FLOOR VENTS

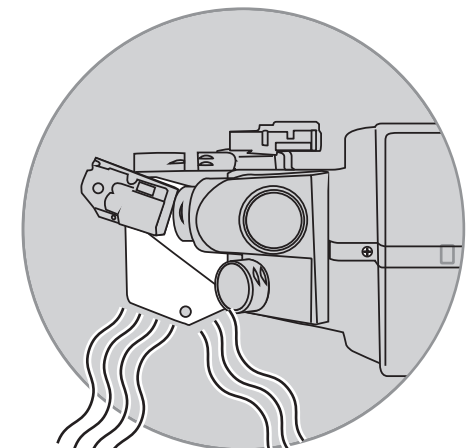

BENCH CALIBRATION & FUNCTION TESTING

• Function Test, Steps 4 and 5

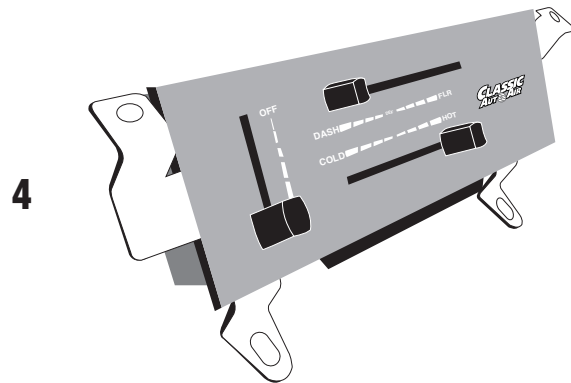

4

Move TEMP knob to HOT

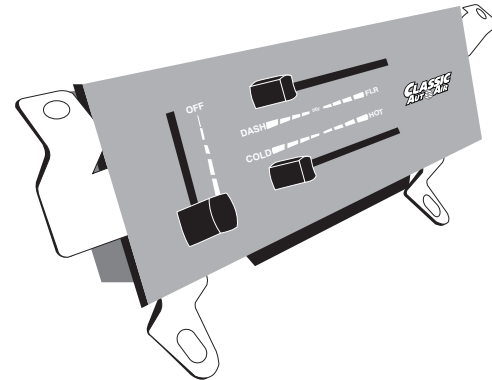

5

Move TEMP knob to COLD

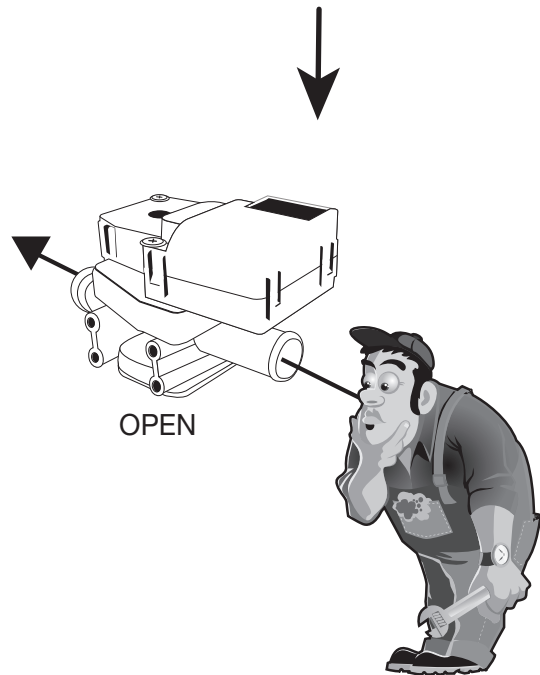

OPEN

You will be able to see through water valve passage

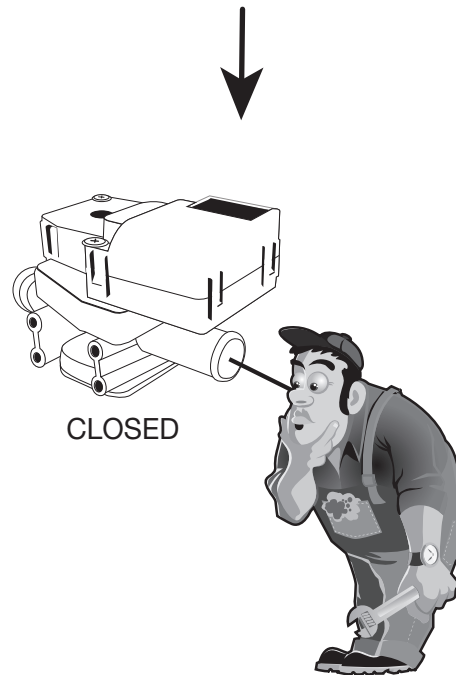

CLOSED

You will NOT be able to see through water valve passage

Return all wiring harnesses, water valve, and ECU to their original bags/boxes (this keeps them organized for future installation steps).

Your controls are now fully calibrated to your unit. Please refer to the next steps in your installation manual for installing the system in your vehicle.

NOTE: IF DURING ANY OF THESE STEPS YOU DO NOT GET THE CORRECT OUTCOME, PLEASE CALL TECH SUPPORT BEFORE INSTALLING INTO VEHICLE. 1(866)435-7801

NOTE: Two people are needed for this step!

Place evaporator on floor panel. Roll unit up behind the glove box opening, inserting tubes through the large hole in firewall.

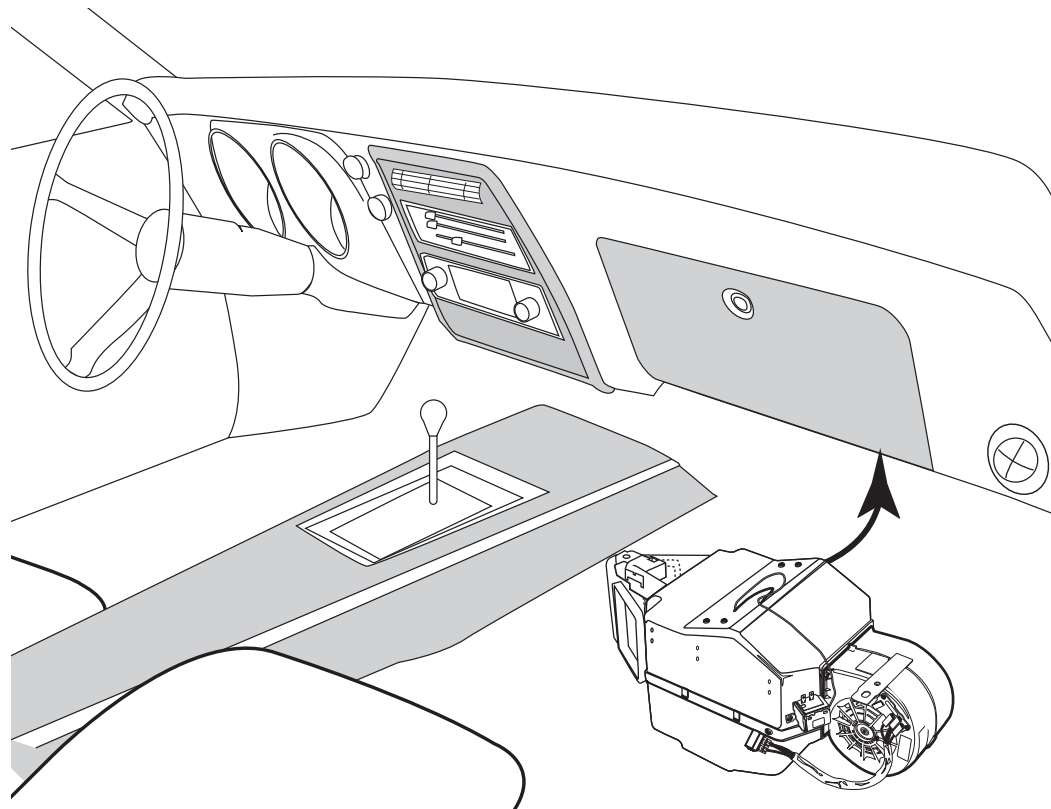

1

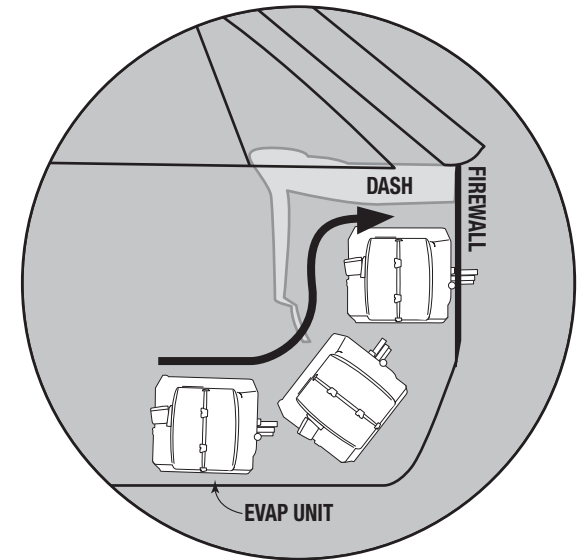

Installing the complete evaporator unit under the dash will go much easier with the help of a friend. Once the unit has been rolled up under the dash, one person can hold the unit in place while the other person can be ready at the firewall area with the included flange nut to secure the unit (see figure 17). Leave Flange nut loose to allow leveling of unit in next steps.

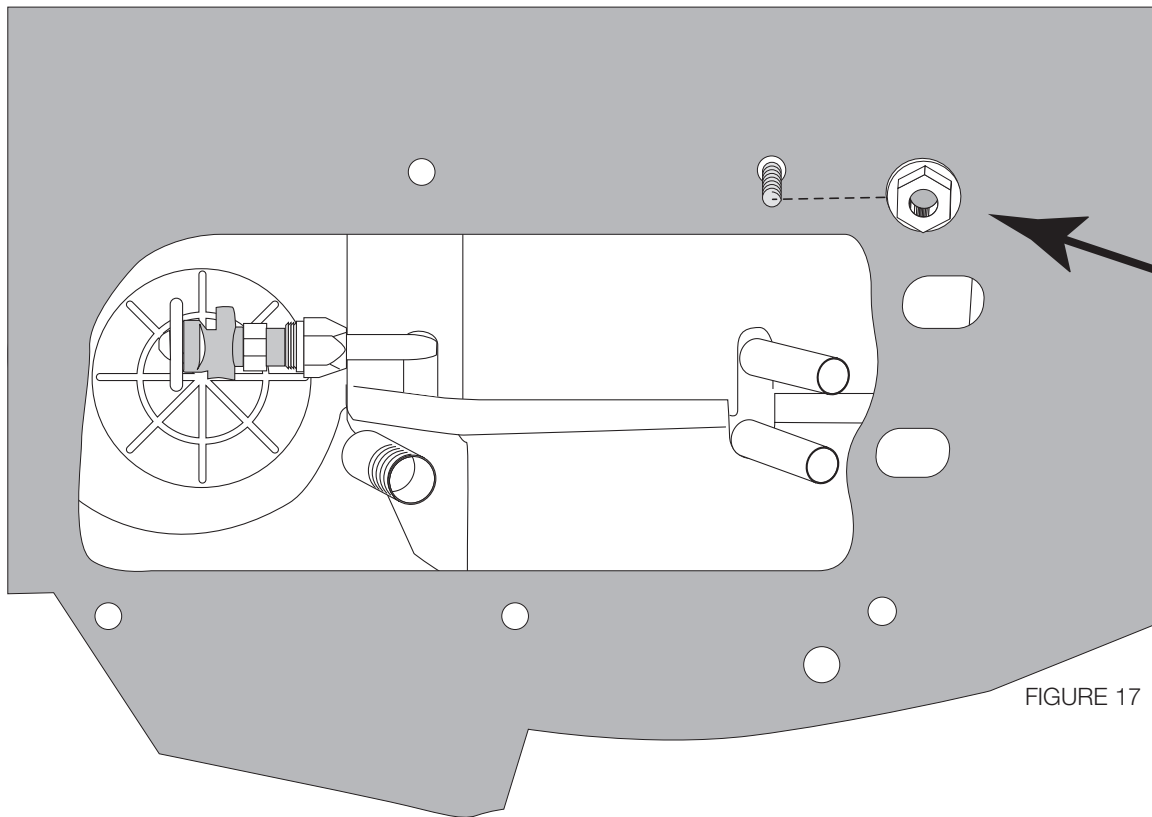
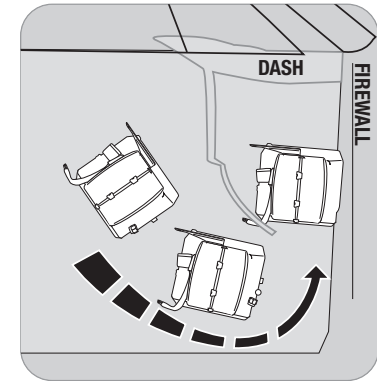
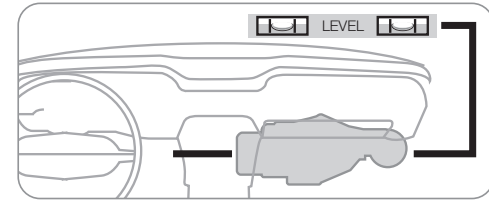
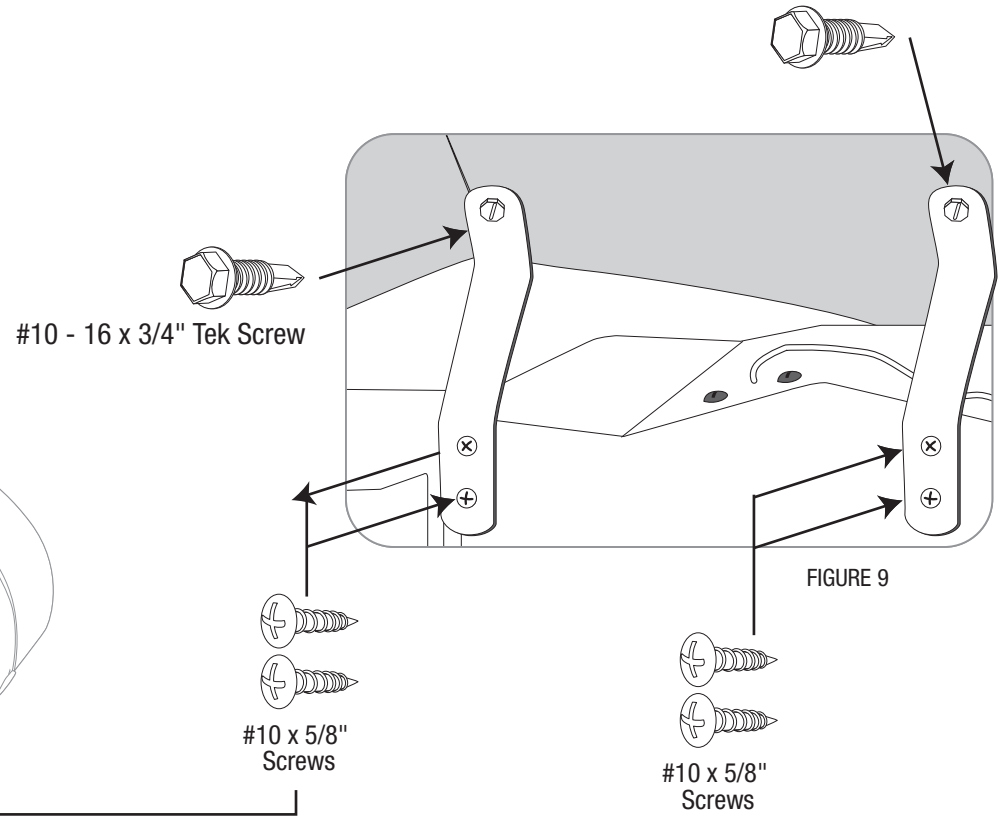
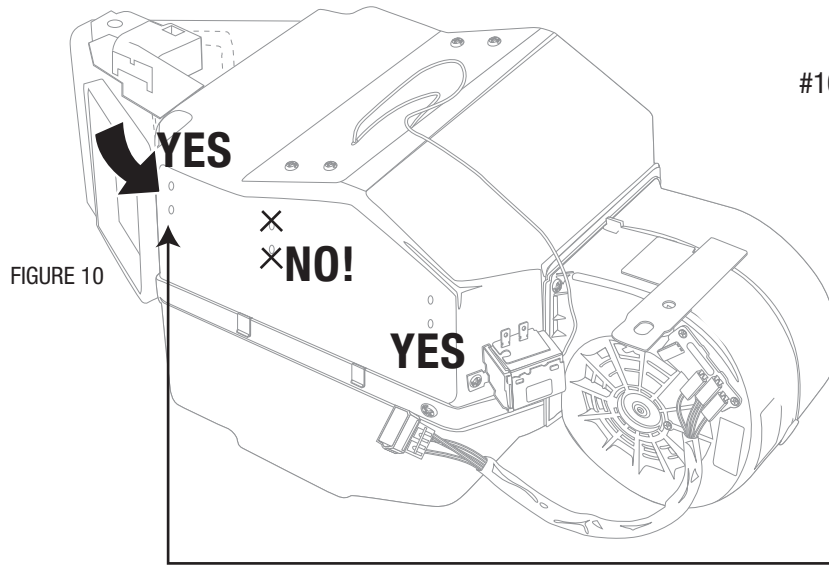

FIGURE 17

Locate in the UPPER MOUNTING BRACKETS and attach to evaporator unit using four #10 - 10 x 5/8" Phillips screws. Attach other end to the cowling with a #10 - 16 x 3/4" Tek Screws (see figure 9). **IMPORTANT NOTE: On the side of the main unit you will see several holes for mounting holes... ONLY USE THE ONES ON THE FAR LEFT AND RIGHT FOR THESE BRACKETS!** Do not tap into the other holes for any reason (see figure 10). Also, use a screwdriver and hand-power and do not over-tighten so you don't strip the holes.



Be sure to align the evaporator unit level with the bottom of dash as shown above, with a small degree of tilt toward the back to allow proper drain of condensation.



Install liquid tube onto the Expansion valve (TXV) as shown. Use #6 o-ring and (2) drops of mineral oil on the o-ring and tighten securely.

Install Suction Tube to the outlet on the unit as shown. Use #10 o-ring and (2) drops of mineral oil on the o-ring and tighten securely.

Locate Sensing Coil attached to Expansion valve (TXV) and utilizing Bulb Clamp, attach to the Suction Tube.

CAUTION: THE SYSTEM WILL NOT FUNCTION PROPERLY IF THE SENSING COIL IS NOT CLAMPED IN THE CORRECT POSITION. SEE PICTURE.

Wrap Suction Tube and Sensing Coil with the refrigerant tape provided. Be sure that all of the exposed metal is covered.

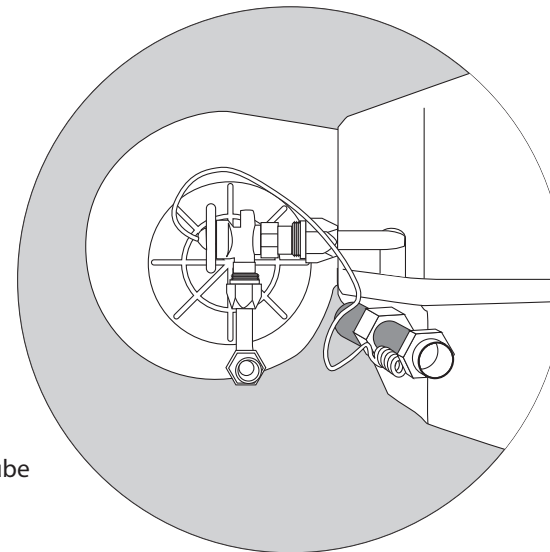
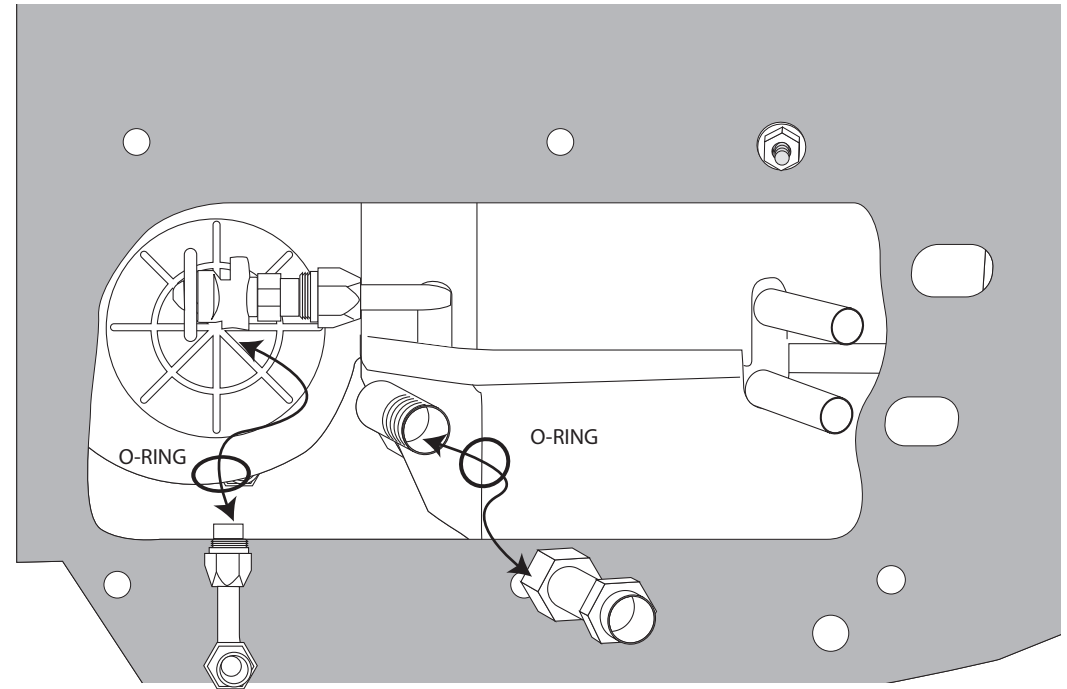

Reminder...
Use two
wrenches to
tighten o-ring
fittings

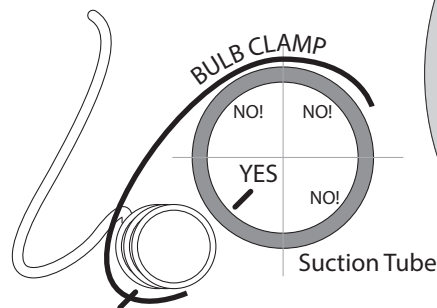
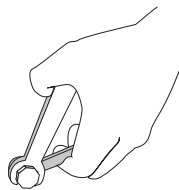

Installing the Drain tube



THIS IS FROM INSIDE THE VEHICLE!

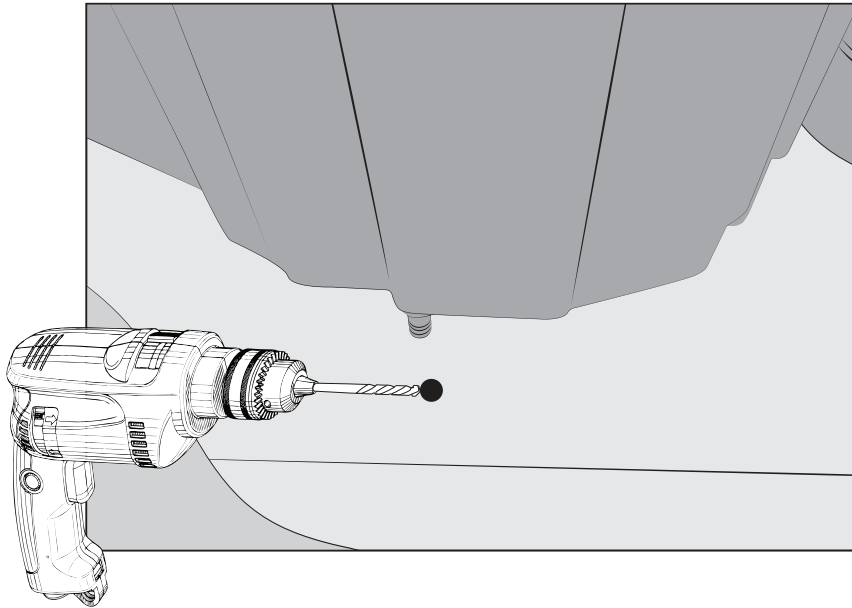

Mount Evaporator level to firewall.

Locate Drain nipple on Evaporator and drill a 1/2" hole below the nipple on the firewall. This will allow condensation to drain properly.

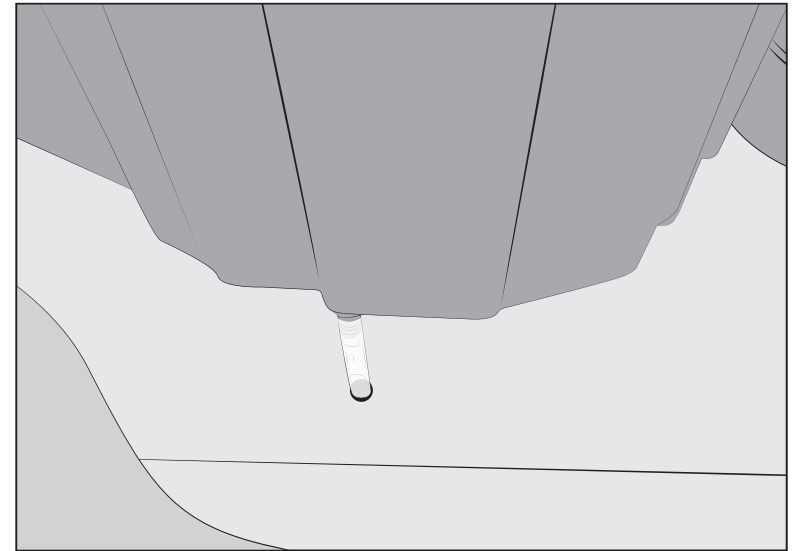

Attach 1/2" clear drain tube to Evaporator nipple and run through 1/2" hole you just drilled.

All condensation will now drain out into the engine bay.

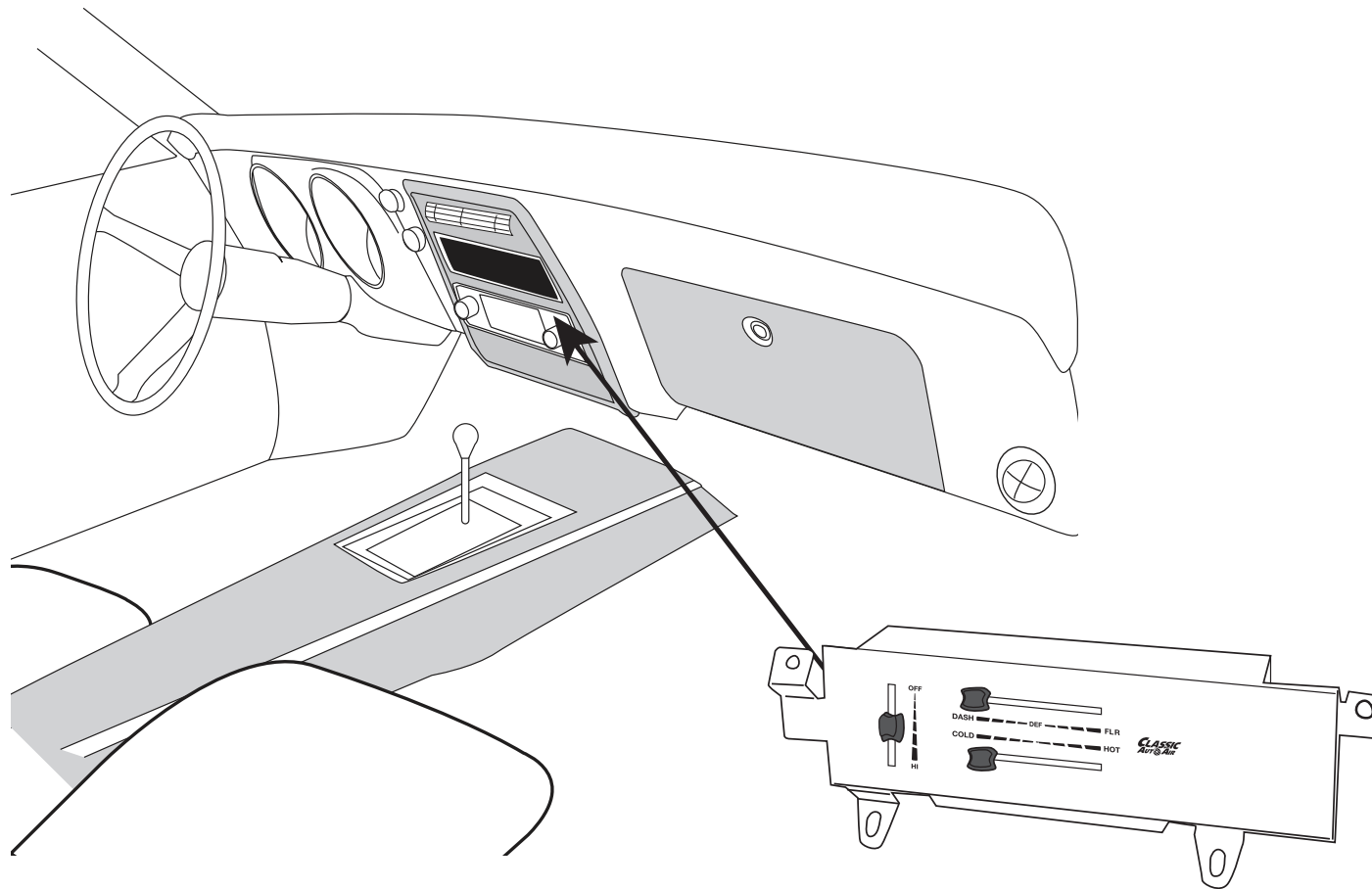

Illustrations NOT shown actual size



THESE ARE THE PARTS YOU WILL FIND IN BAG KIT C

You will use all of these parts and hardware during the next series of installation steps.

The ECU will be shipped in it's own box, along with the calibration key.

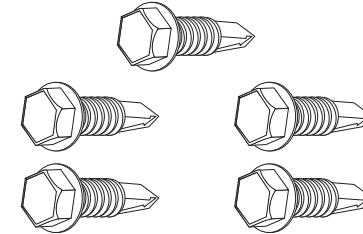
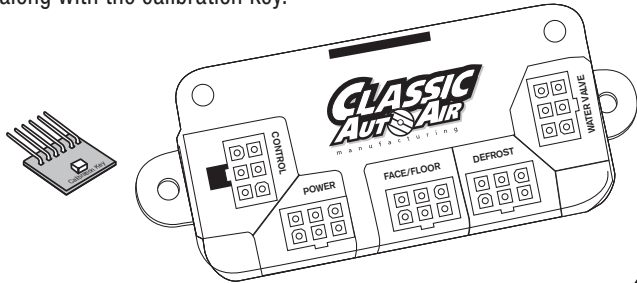

Five #10 - 16 x 3/4" Tek Screws

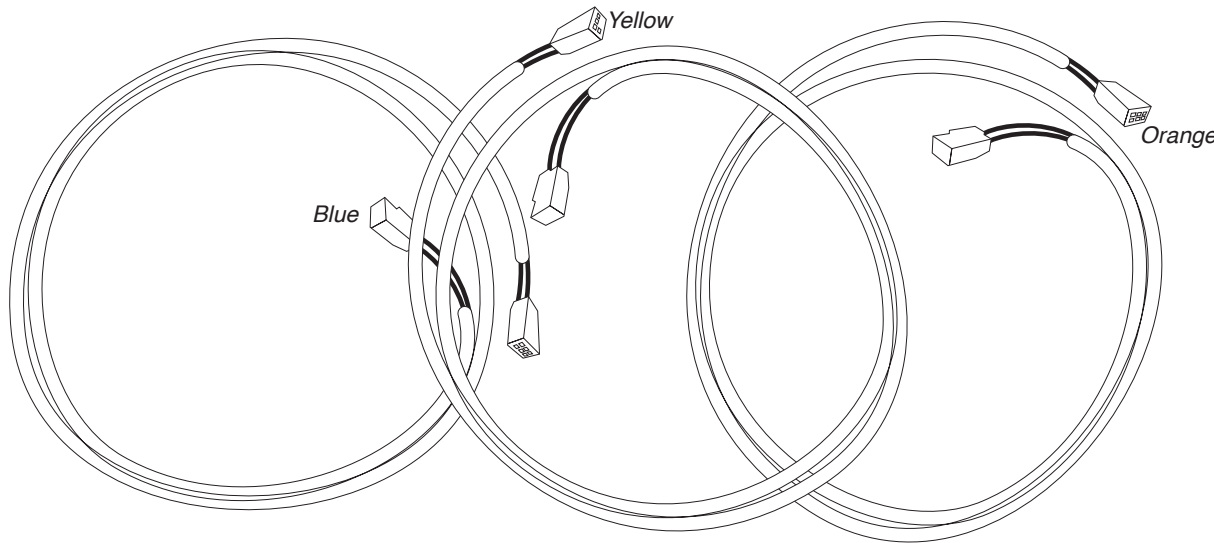

EZ Wire Harness System

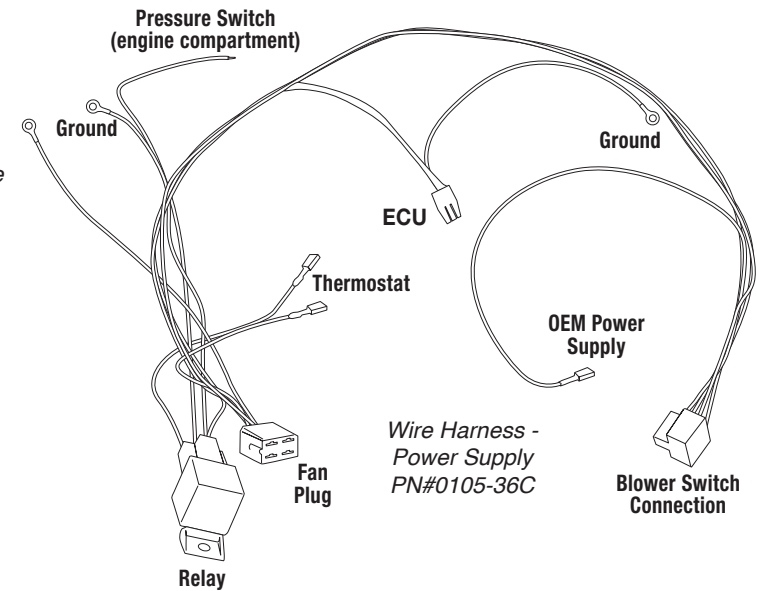

Wire Harness - Power Supply PN#0105-36C

Illustrations NOT shown actual size

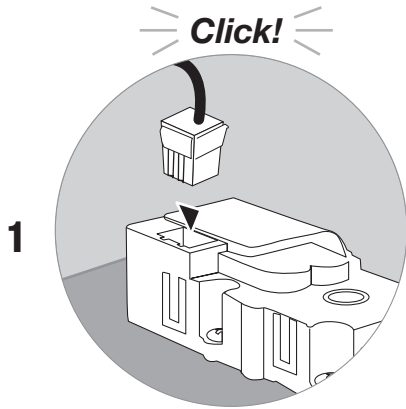

Connect Blue Harness into Defrost/Heat Servo Motor

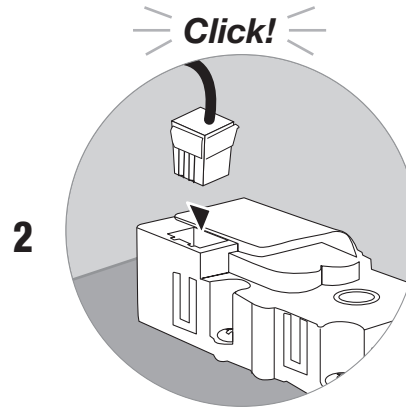

Connect Yellow Harness into Face/Floor Servo Motor

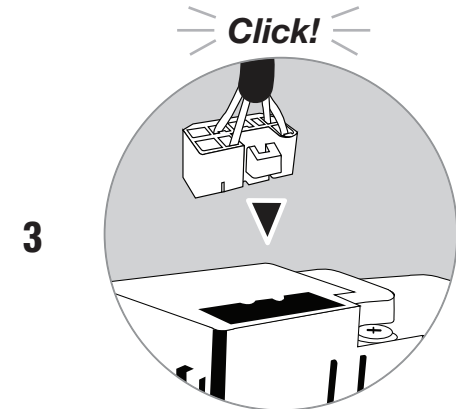

Connect Orange Harness into water valve

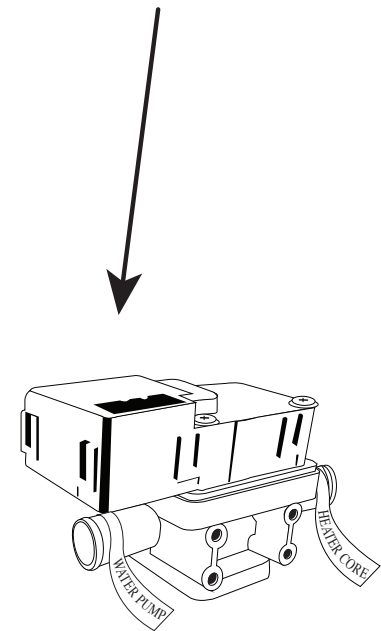
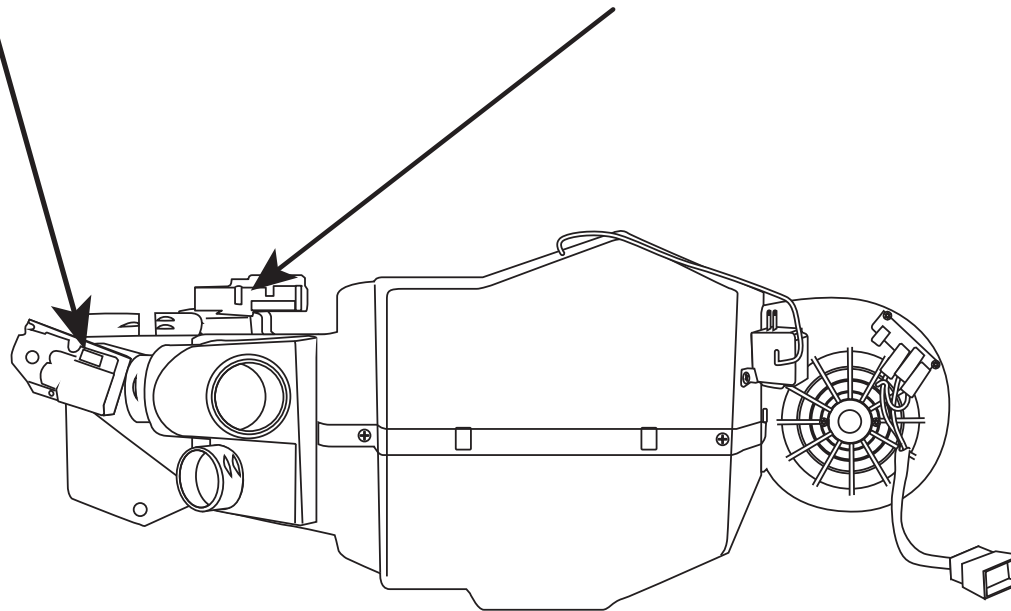

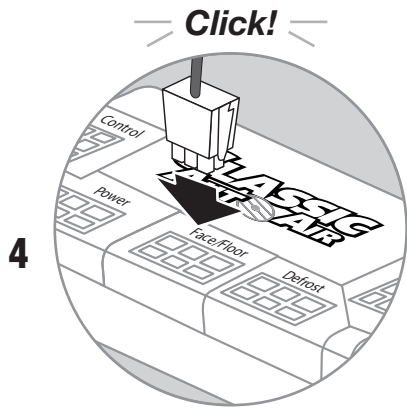

4 Connect Yellow Harness into Face/Floor Port on ECU

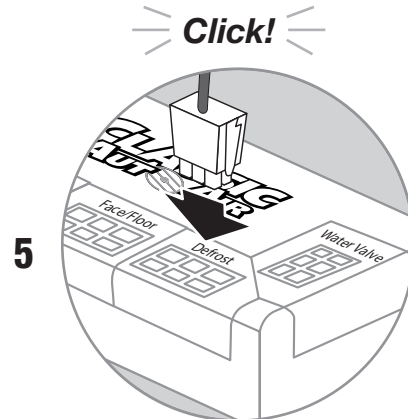

5 Connect Blue Harness into Defrost/Heat Port on ECU

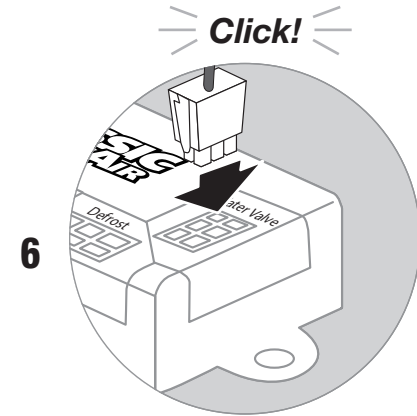

6 Connect Orange Harness into Water Valve Port on ECU

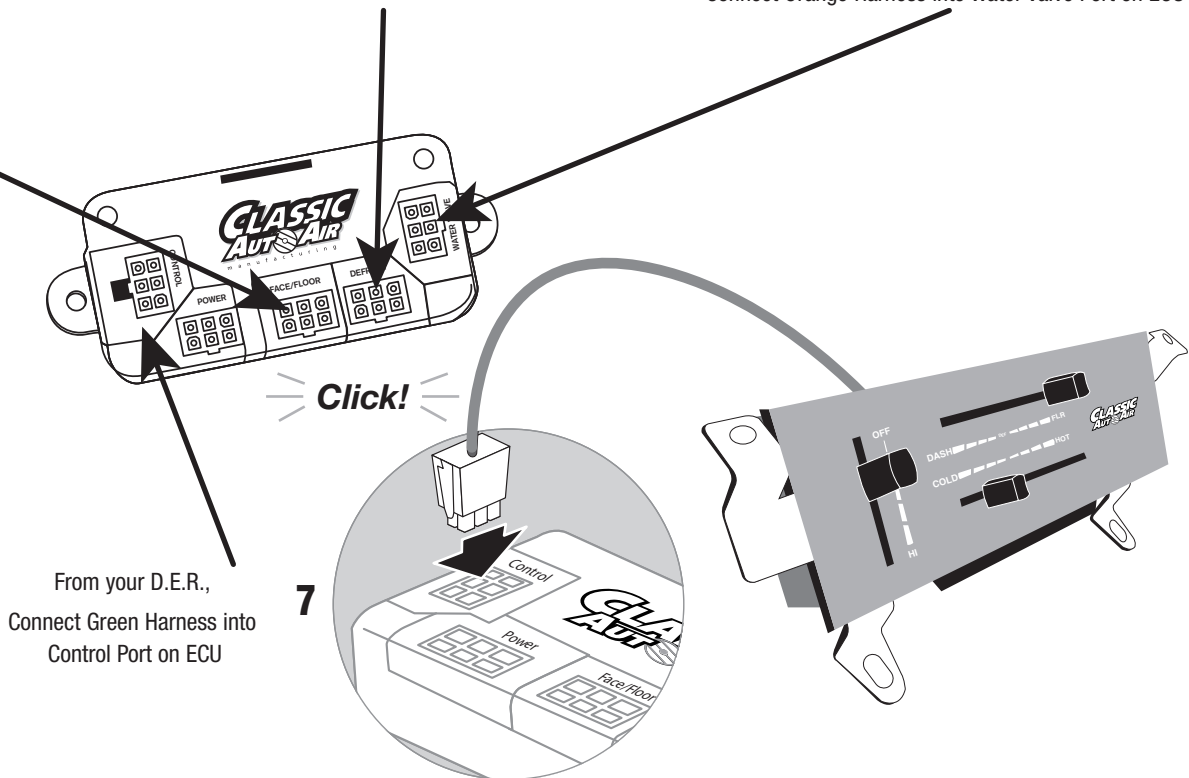

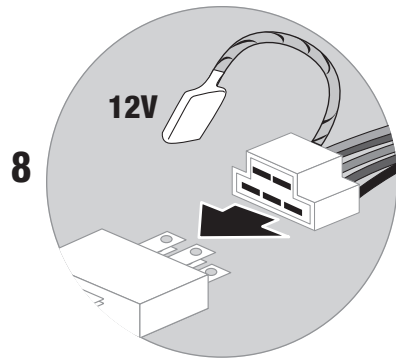

8
Connect corresponding Fan Switch harness to the Bower Switch on Controls
Connect Power lead to 12V.

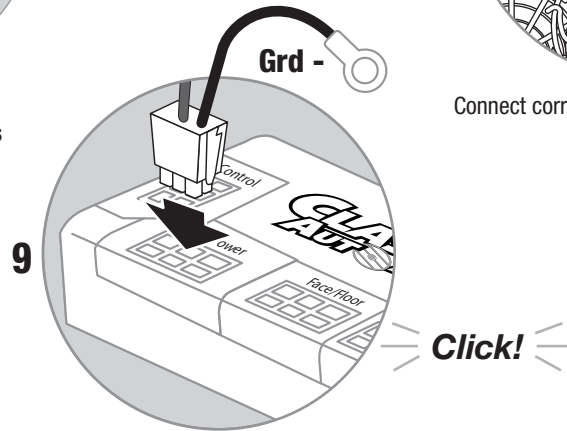

9
Connect red tagged power harness to POWER port on ECU.
Connect ground.

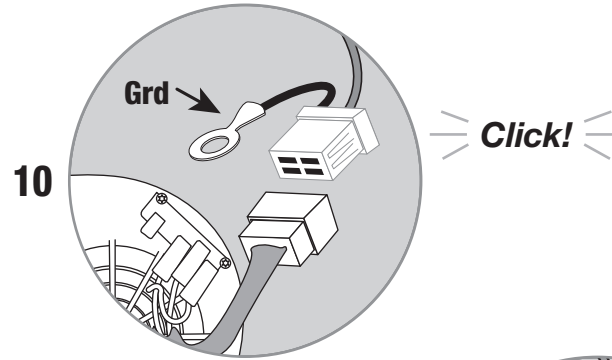

10
Connect corresponding fan motor harness.
Connect ground.

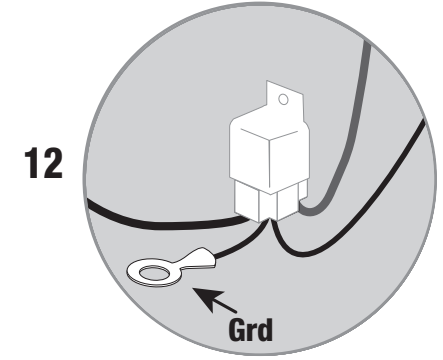

12
Connect ground.

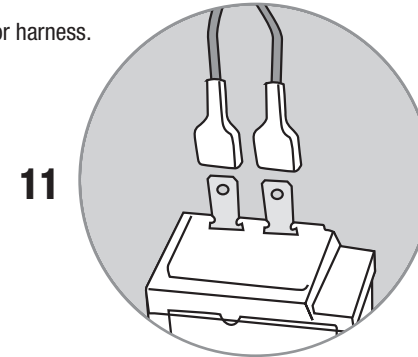

11
Connect both BLUE leads into thermostat
(either lead into either terminal)

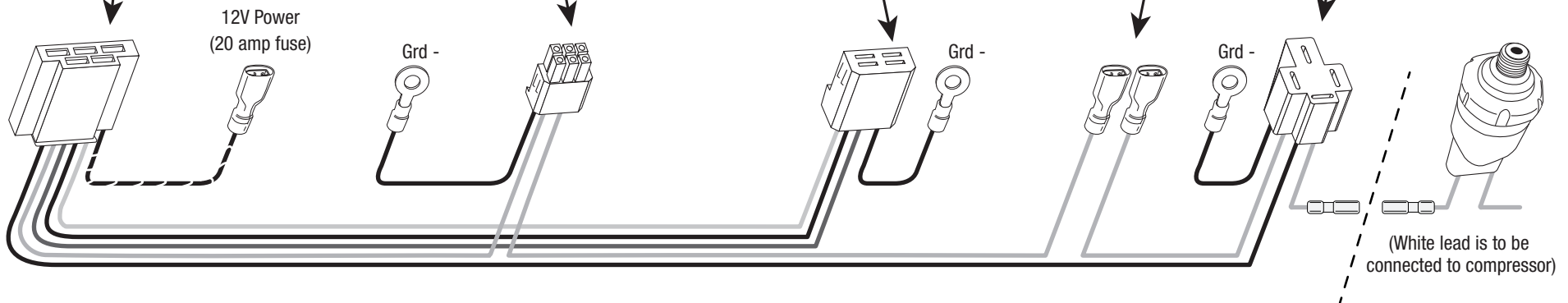

THESE ARE THE PARTS YOU WILL FIND IN BAG KIT D

You will use all of these parts and hardware during the next series of installation steps.

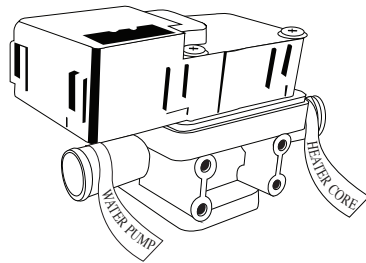

Electronic Water Control Valve
PN#16-1081-2

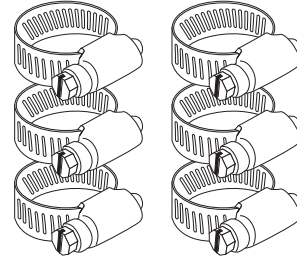

Six Worm Gear Clamps



Clear Plastic Drain Tube

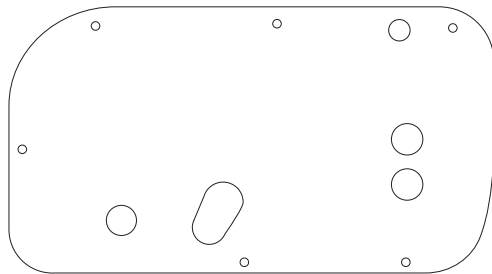

Firewall Block Off
PN#10-1049-1

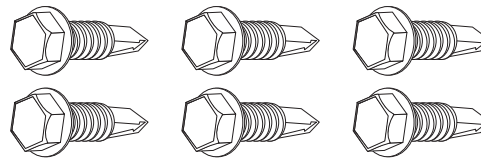

Six #10 - 16 x 3/4" Tek Screws



Refrigerant Tape

Illustrations NOT shown actual size

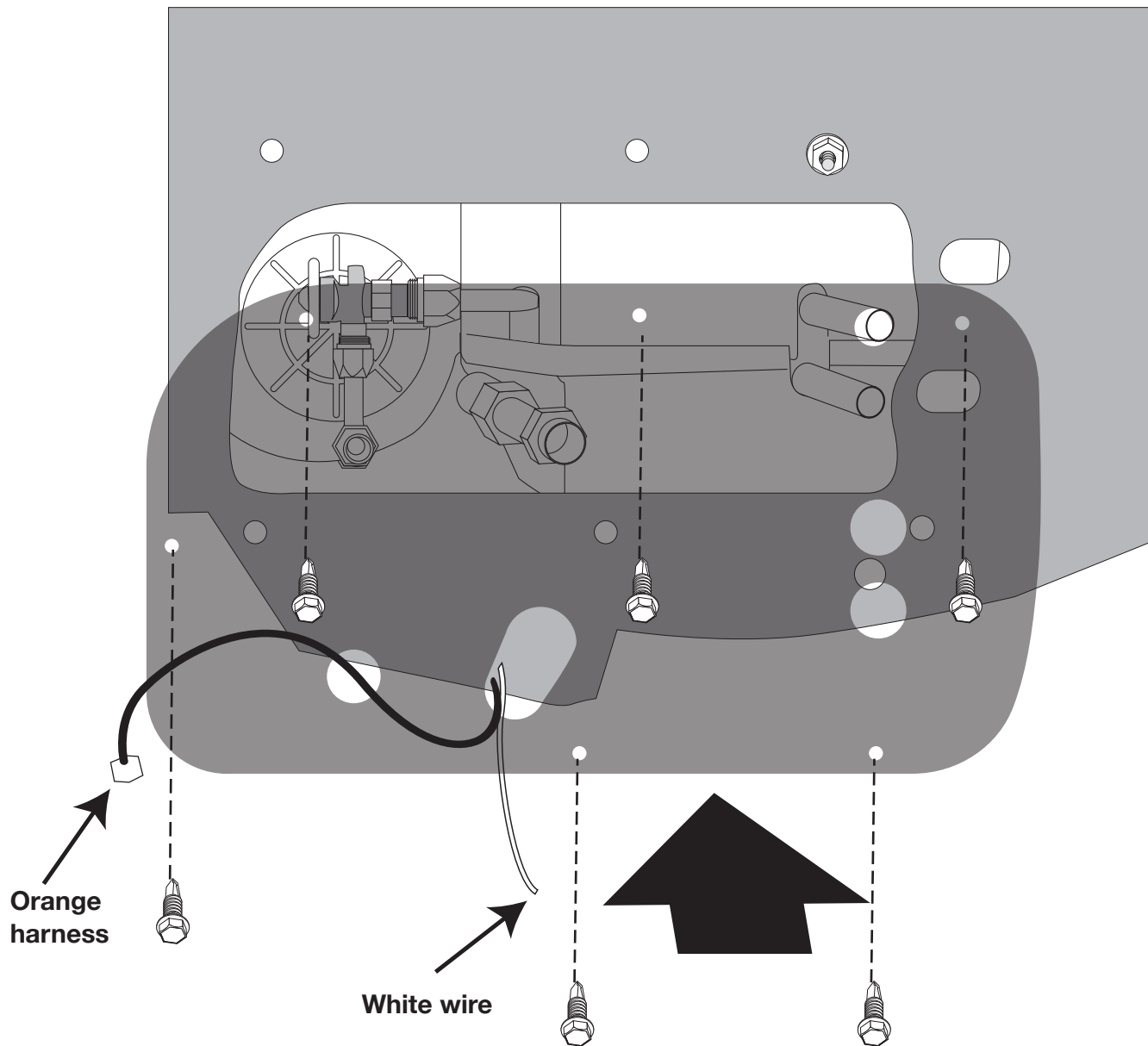

In **Bag Kit D** you'll find the firewall block off. Install this over the hose connections coming through the firewall within the engine compartment. Attach with six #10 - 16 x 3/4" Tek screws.

TIP: Route ORANGE cable through the block off plate (it will be plugged into the electronic water valve).

The loose white wire from main power harness can be fed through the same hole (as shown below).

IMPORTANT NOTICE: PROPER INSTALLATION OF WATER VALVE

Your water valve MUST be installed per these instructions!... (If not, your system will not work properly.

The **lower** heater tube connection on firewall will be routed to the water connection on intake manifold using 5/8" dia. heater hose with the supplied worm gear clamp.

The **upper** heater tube connection on the firewall will be routed to the water valve connection labeled **heater core**, using a 6" piece of 5/8" heater hose attached with supplied worm gear clamp.

Connect the remaining outlet on water valve labeled **water pump** to the water pump using 5/8" dia. heater hose with the supplied worm gear clamp.

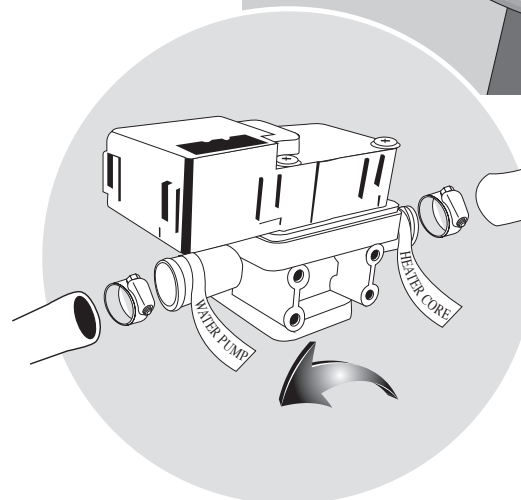
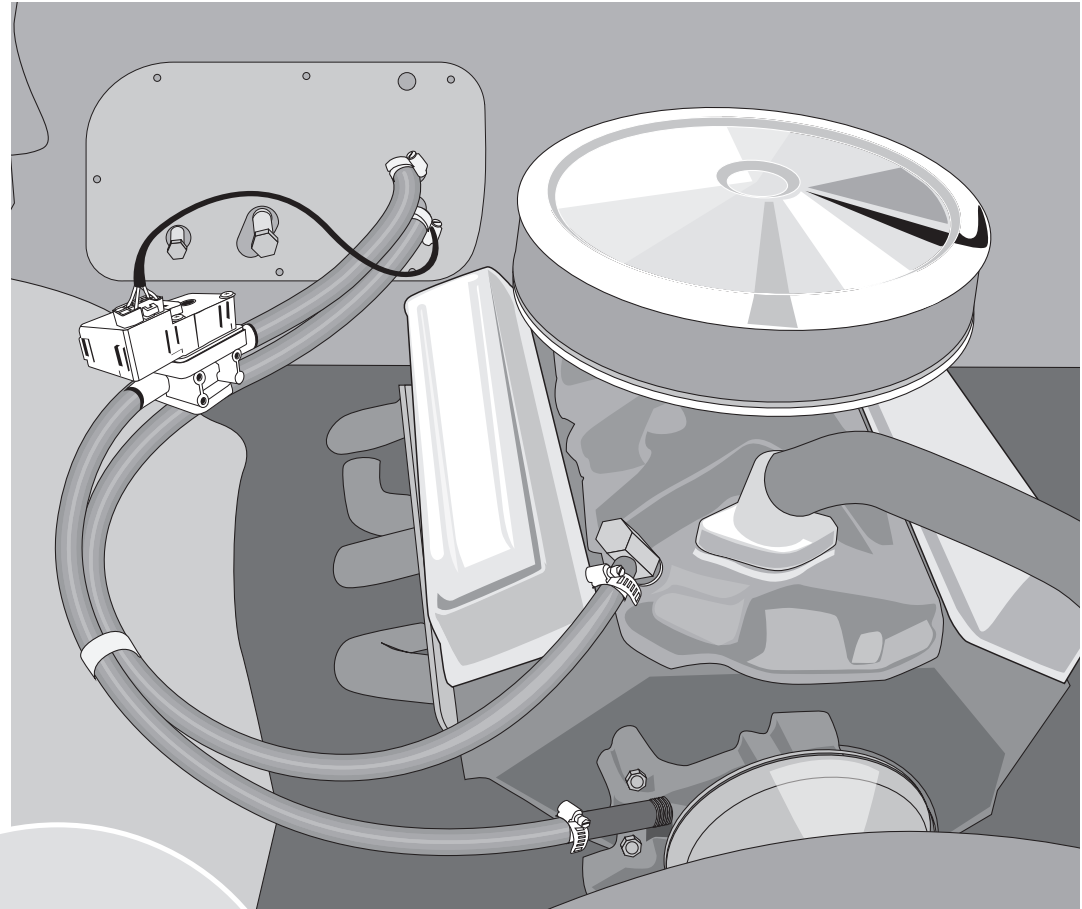

**FOLLOW THESE
TAGS... CHECK IT
TWICE BEFORE
PROCEEDING!**

THESE ARE THE PARTS YOU WILL FIND IN BAG KITS E, F, and G

You will use all of these parts and hardware during the next series of installation steps.

Bag E

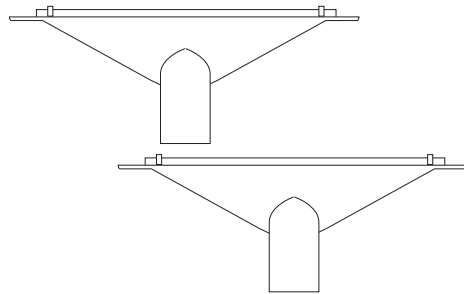

Two Defrost Diffuser
PN#2-1054-2

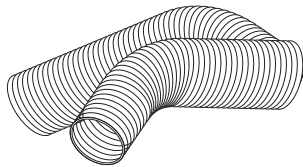

Two Duct Hoses, 2" I.D.

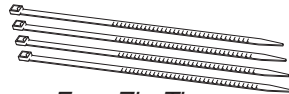

Four Zip-Ties

Bag F

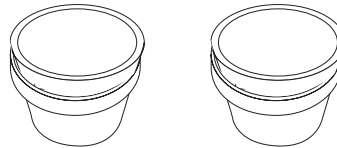

Ball Louver Adapters
(2 piece assembly)
PN#2-1055-1

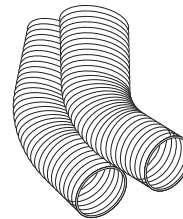

Two Duct Hoses, 2" I.D.



Four Zip-Ties

Bag G

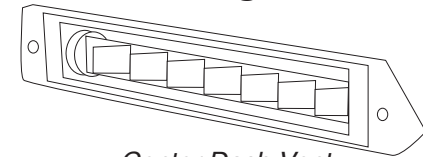

Center Dash Vent
PN#2-1054-1

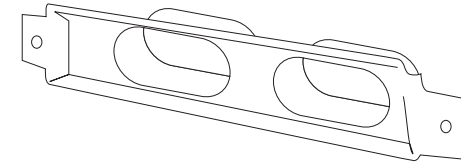

Center Dash Vent Adapter
PN# 2-1054-3

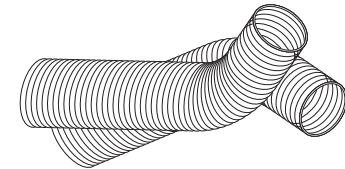

Two Duct Hoses, 2" I.D.

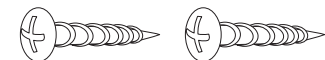

Two #6-20 x 1" Phillips Screws



Two #10 - 10 x 5/8" Phillips Screws



Four Zip-Ties

Illustrations NOT shown actual size

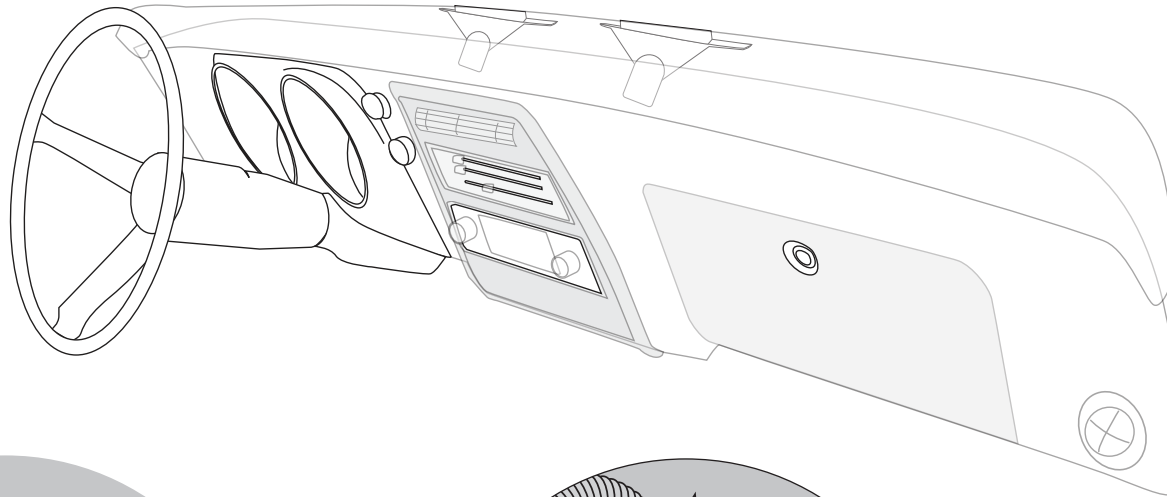

1

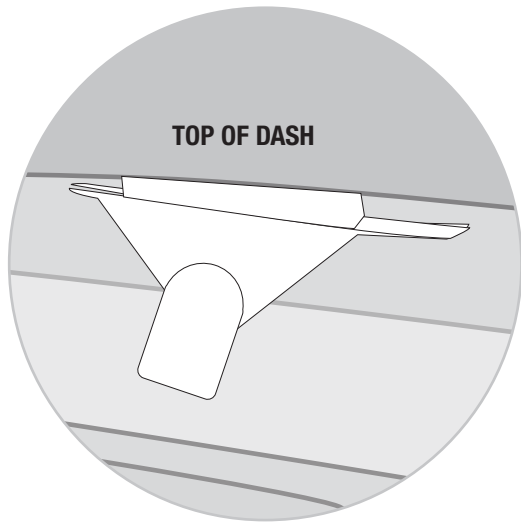

Push defrost adapters onto lip of dash tab (below defrost vents, inside of dash), S-clips (already installed) will hold the adapters securely

2

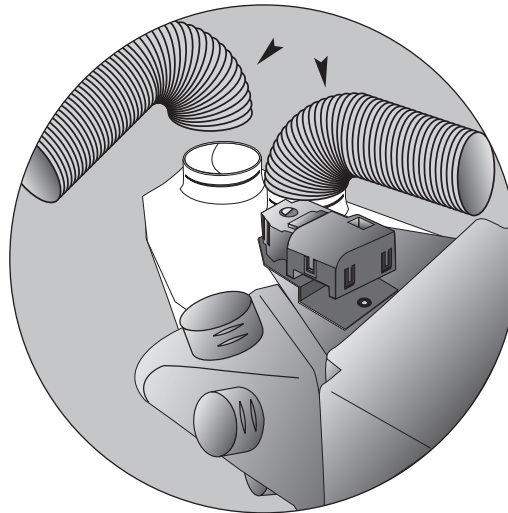

One end of the duct hose is installed over the defrost/heat duct assembly outlets on the main unit.

3

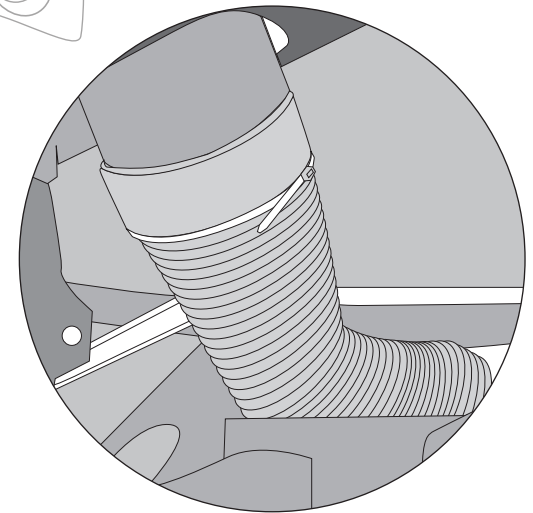

Next route the duct hoses from the defrost/heat duct assembly upward toward defrost vents. Attach the flex hose to the defrost diffuser using zip-ties on both ends.

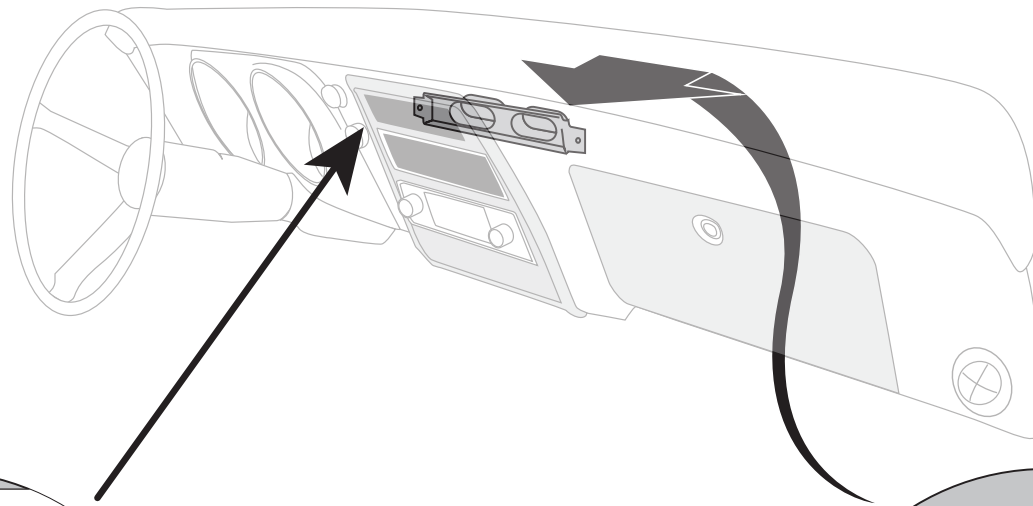

1

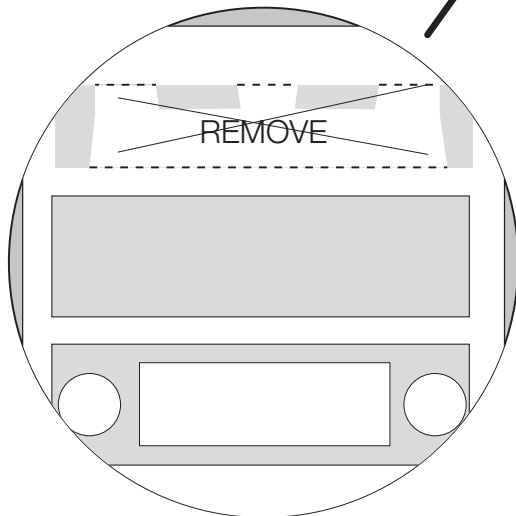

Above the control panel opening, cut out the center and down to the control opening of the block off, as shown for the center louver assembly. Follow dash lines in drawing.

2

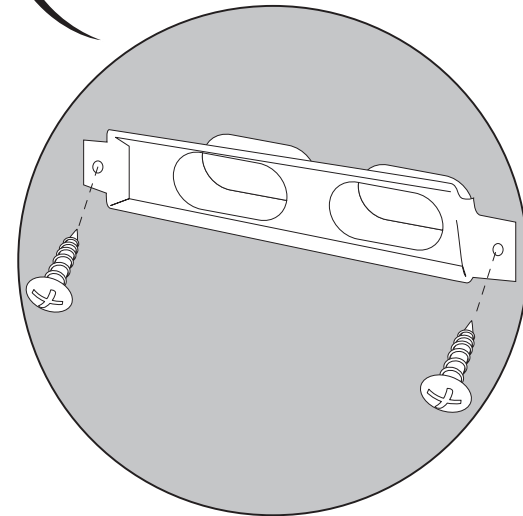

Feed Center Dash Vent Adapter PN# 2-1054-3 from behind aligning screw holes from front and mount using Two #10 screws.

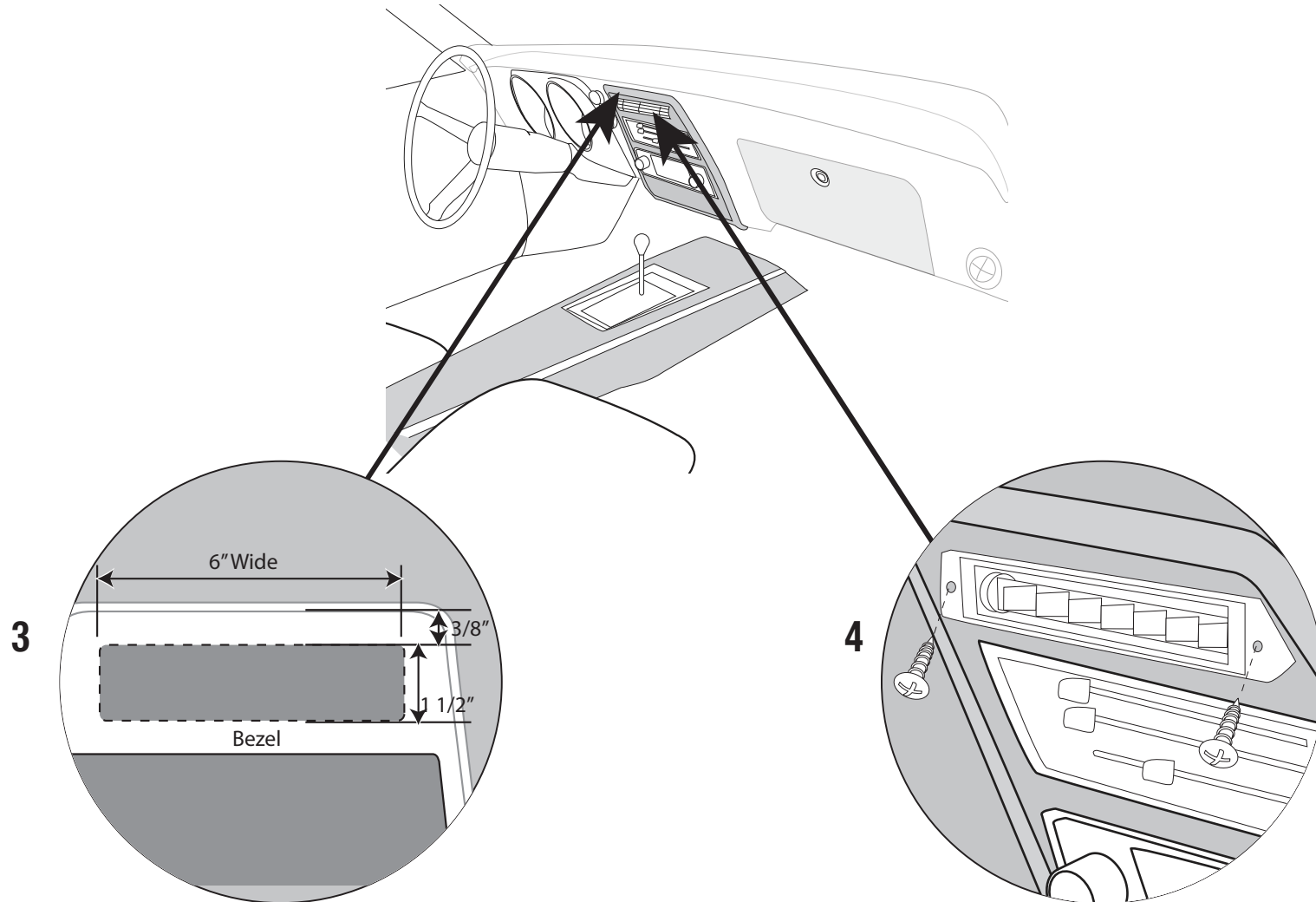

Bag Kit G: Installing the center louver vent requires a small amount of cutting to the dash support. If you haven't already, remove the main bezel.

Locate the center louver assembly and (2) #6 x 1" pan head philips screws. Place louver assembly over the trim bezel and drill (2) 1/8" dia holes using the trim bezel as guide. Attach louver assembly using (2) #6 screws.

Insert original ball into the original louver housing. Attach hose adapters to the back of housing (applying pressure will keep your louver ball in place).

Reinstall louver assemblies into original holes using original hardware.

Route supplied flex hoses as shown below. Take your time and route them so they don't become kinked or torn.

During installation of the hoses be aware of the eventual movement of the wiper arm components.



The smoother the route of the flex hoses the better the airflow.

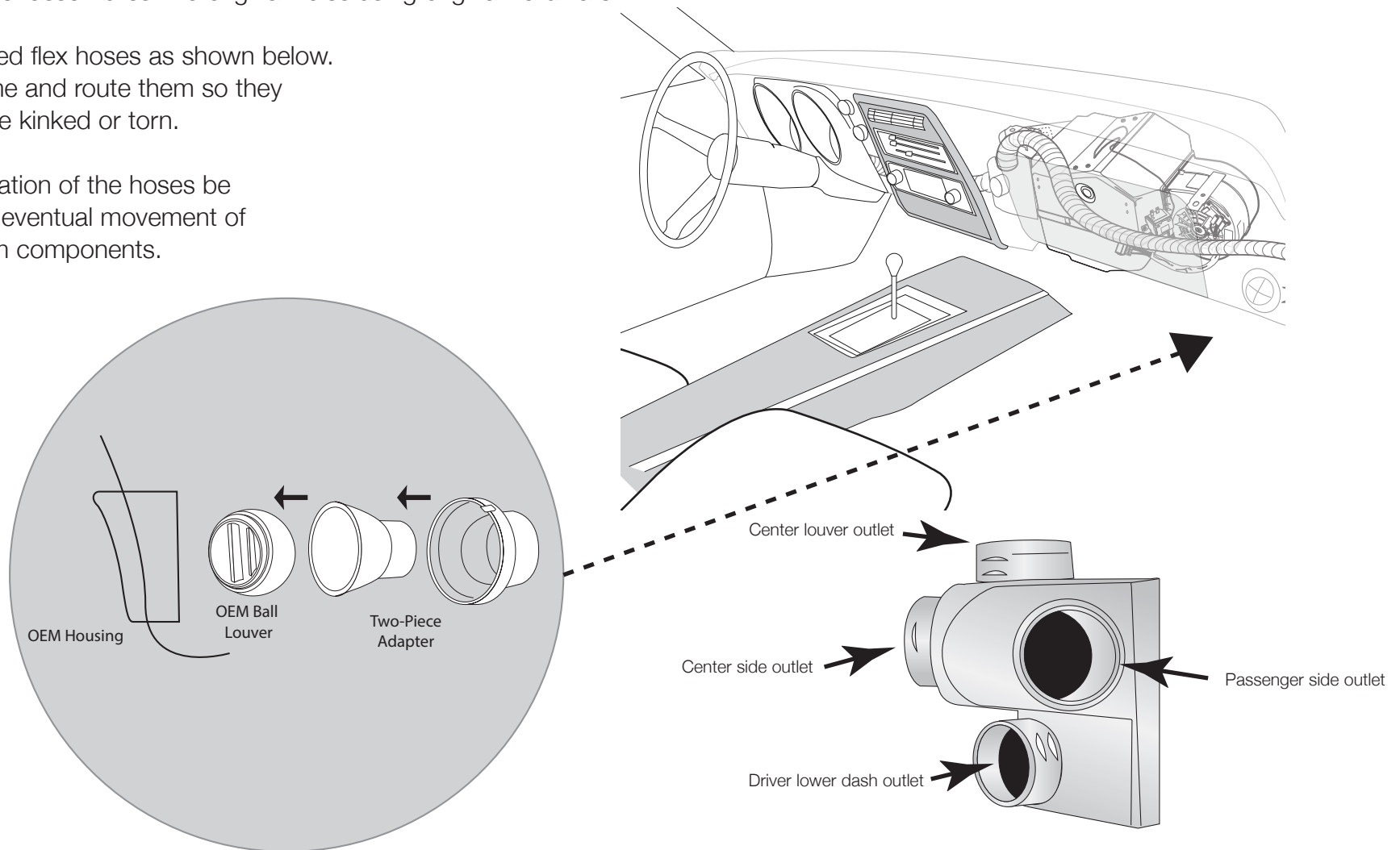



THESE ARE THE PARTS YOU WILL NEED FOR THE ENGINE COMPARTMENT INSTALLATION

You'll find all of these parts within the main box

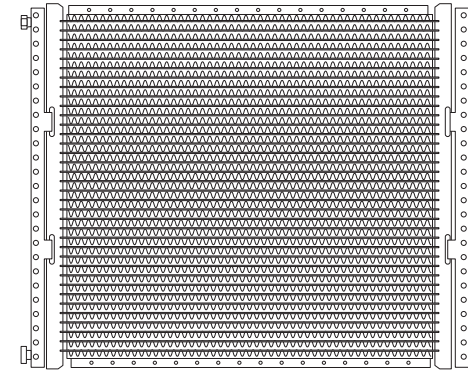
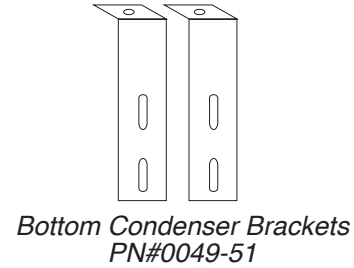
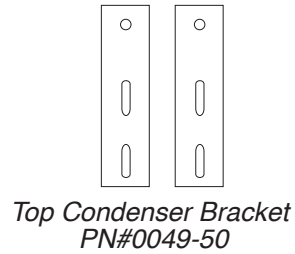
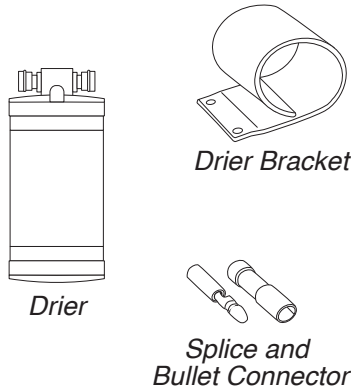

Condenser
PN#11-1089

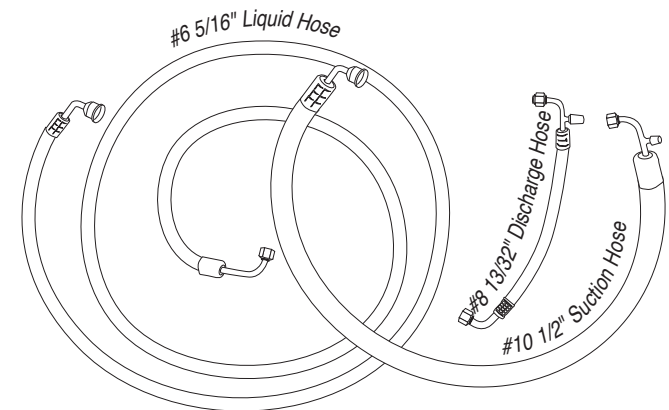
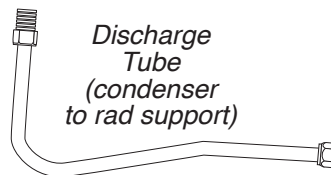
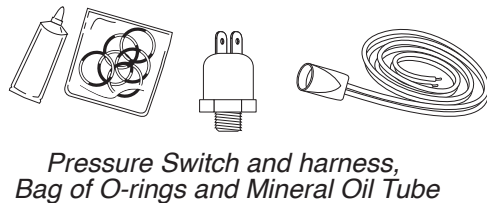
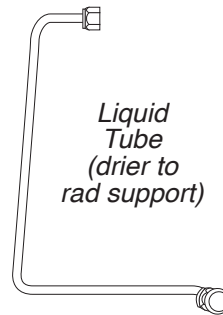
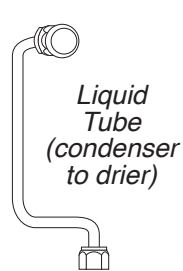
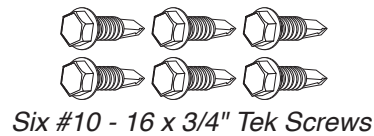
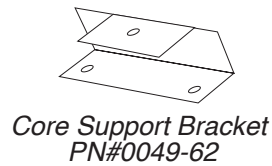

Three Refrigerant Hoses

DRIER AND CONDENSER PREPARATION. You can perform most of the following steps on a clean flat surface like a workbench. Lay the condenser down so that both hose connections are on the left side (the larger connection will be on top). The drier is conveniently mounted on the left hand side of the condenser. First insert the drier into the drier mounting bracket (it's basically a sleeve for the drier). Attach the drier liquid tube to the drier and also to the connection on the condenser (tighten connections at either end using supplied o-rings on both ends and a few drops of mineral oil to each o-ring). With these two components combined it will be easy to find the correct place to attach the drier bracket to the condenser with the included #10-20 x 1/4" screws (attach drier and bracket from the front of the condenser).

PRESSURE SWITCH: Screw the high-pressure switch into the port on the top of the drier. Go ahead and plug the pressure switch harness into the switch at this time (black electrical boot with two long white wires).

BRACKETS: Install the upper condenser bracket using four #10 - 20 x 1/4" screws in the top two holes on each side. Next, attach the lower brackets using the bottom two holes, with the same size screws. These brackets have a bend that will face away from you.

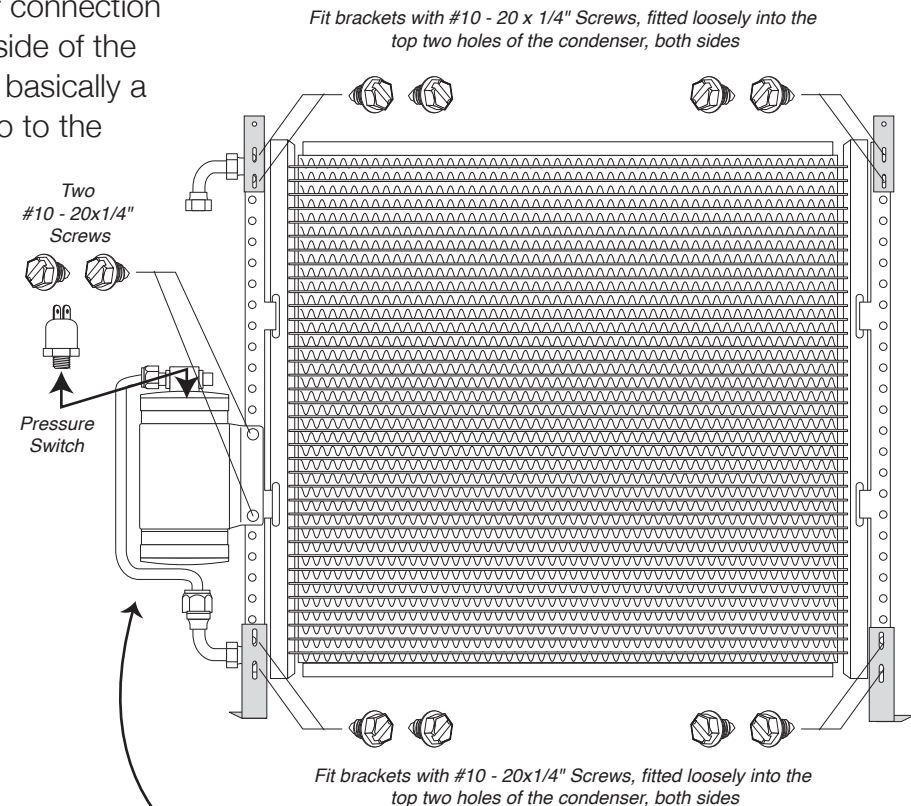
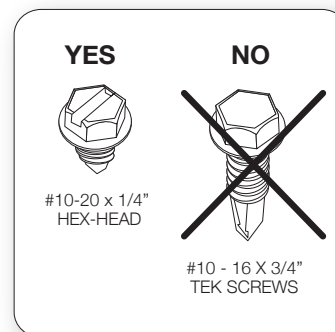

You can easily find the correct position for mounting the drier to the condenser by using the drier liquid tube as a gauge.

Remove the hood latch assembly. Retain original hardware. Slide condenser assembly down in front of the radiator.

Locate condenser in the center of the radiator. Attach top condenser brackets to the bulkhead using (2) #10 Tek screws.

Located behind the air dam and at the lower radiator bulkhead, attach the lower condenser brackets using (2) # 10 Tek screws.

Reinstall hood latch assembly using original hardware.

Locate the Liquid tube, Discharge tube, (1) #6 o-ring, and (1) #8 o-ring. Attach Liquid tube to the drier using the #6 o-ring and a few drops of mineral oil. Attach Discharge tube to the condenser using #8 o-ring and a few drops of mineral oil.

Locate the tube support bracket, the tube clamp, and (2) #10 x 3/4" tek screws, and (1) #10 x 1/2" hex head screw.

Attach the support bracket to the radiator bulkhead using (2) #10 x 3/4" tek screws.

Attach liquid and discharge tubes using the tube clamp, using (1) #10 x 1/2" screw.

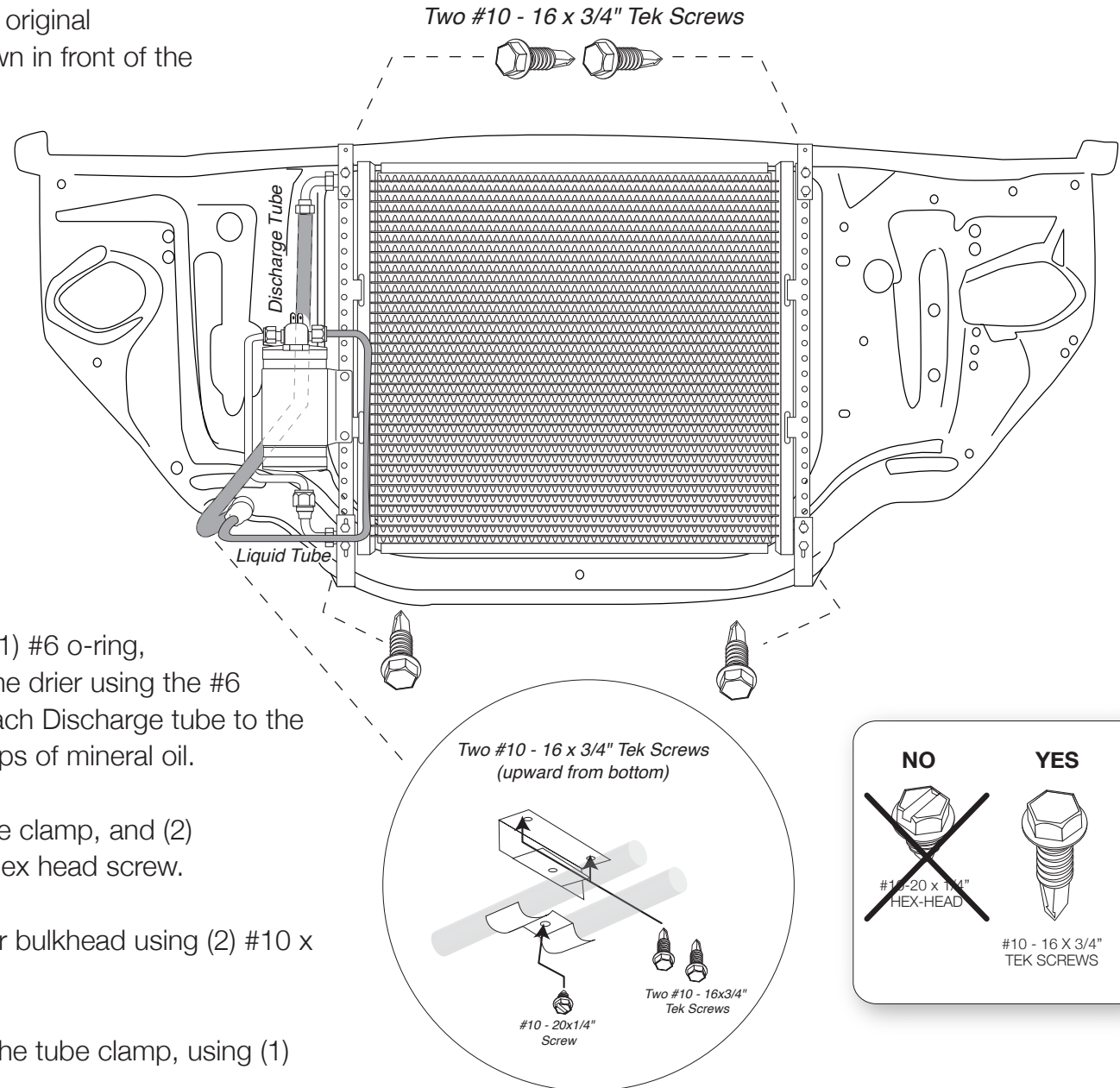

Connecting the Hoses

Install the compressor kit. Included was a premium compressor kit with all the parts you'll need to install the compressor. This kit includes instructions specifically written for your engine. Once you've installed the complete compressor kit, continue on to connecting the hoses.

CONNECTING THE HOSES:

Based on PASSENGER or DRIVERS SIDE compressor mounting see illustrations for routing.

The #10 (**LARGEST**) refrigerant hose. Attach end with service fitting to the compressor using (1) #10 o-ring and a few drops of mineral oil. Attach other end to #10 fitting at the firewall. Attach using one #10 o-ring and a few drops of mineral oil. Tighten securely.

The #6 (**SMALLEST**) refrigerant hose. Route behind fender and to the connection on firewall. Attach using two #6 o-ring and a few drops of mineral oil.

The #8 (**MEDIUM**) refrigerant Hose. Route behind fender and to the connection on compressor. Attach using two #6 o-ring and a few drops of mineral oil.

TWO WRENCH METHOD

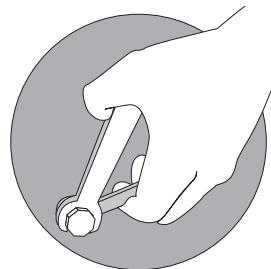

**Reminder...
Use two
wrenches to
tighten o-ring
fittings**

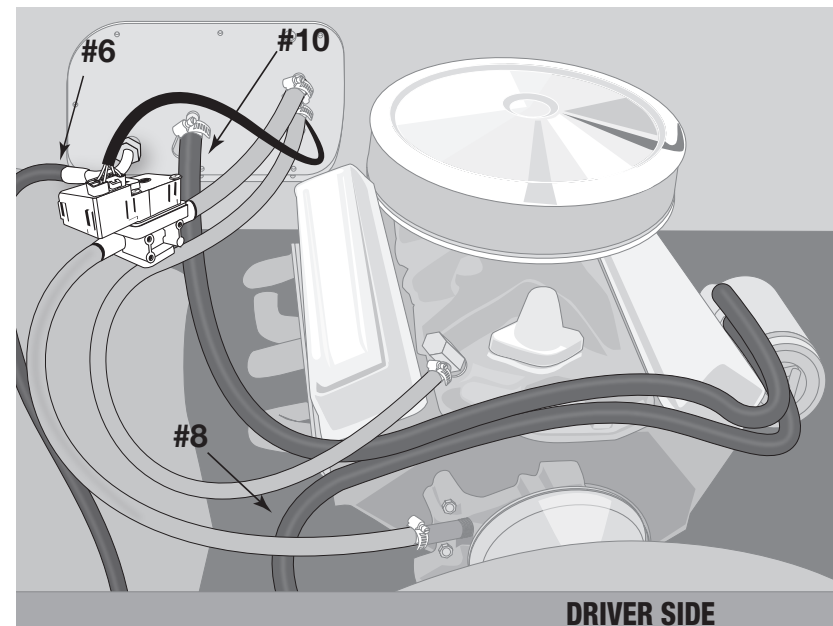
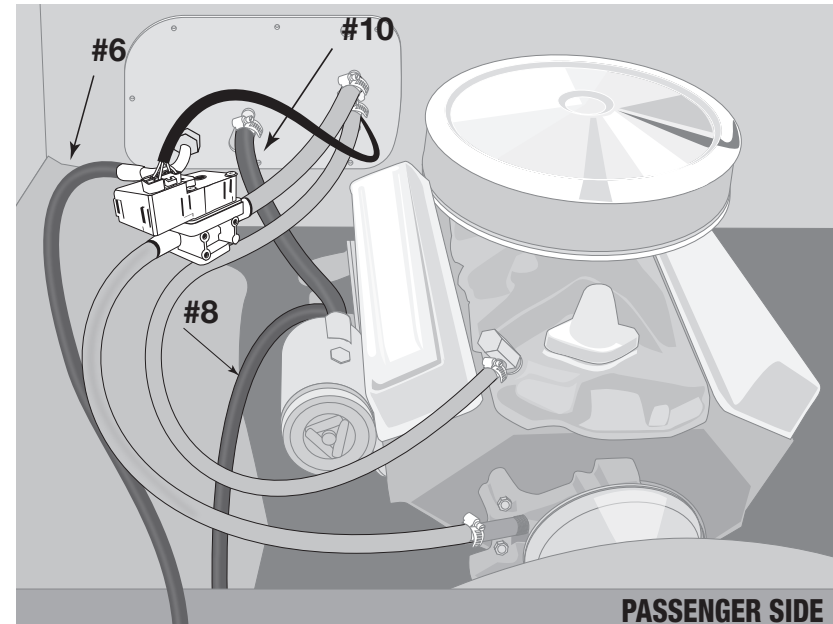

New A/C System Preparation... A MUST READ!

Please read through these procedures before completing this new A/C system charging operation. **A licensed A/C technician should be utilized for these procedures to insure that your new system will perform at it's peak, and that your compressor will not be damaged.**

- 1) Your radiator/cooling system is an integral part of your new system. Please insure that you have a 50/50 mix of distilled water and antifreeze. The heater coil **MUST** be purged (cycle heater control valve) to make sure no water, without antifreeze, is in the heater coil before you charge the A/C system.
- 2) Evacuate the system for 45 minutes (minimum).
-  3) **Your new compressor MUST be hand-turned 15-20 revolutions before and after charging with liquid. Failure to do this may cause the reed valves to become damaged** (this damage is NOT covered by your warranty).
- 4) Your new system requires 134a refrigerant. It will require 1.5 lbs (or 24 oz).
- 5) Your new compressor comes charged with oil - NO additional oil is needed.
- 6) Insure that the new belt is tight.
- 7) **DO NOT CHARGE SYSTEM WITH LIQUID REFRIGERANT!**

RECOMMENDED TEST CONDITIONS: (After system has been fully charged and tested for basic operation)

- Determine the temperature outside of the car
- Connect gauges or service equipment to high/low charging ports
- Place blower fan switch on medium
- Close all doors and windows on vehicle
- Place shop fan directly in front of condenser
- Run engine idle up to approx. 1500 rpm

ACCEPTABLE OPERATING PRESSURE RANGES:

1. HIGH-SIDE PRESSURES (150-275 PSI)
2. LOW-SIDE PRESSURES (10-25 PSI in a steady state)

Readings above are based on an ambient temperature of 90° with an adequate airflow on condenser

CENTERLINE OF THE OIL FILL BOLT

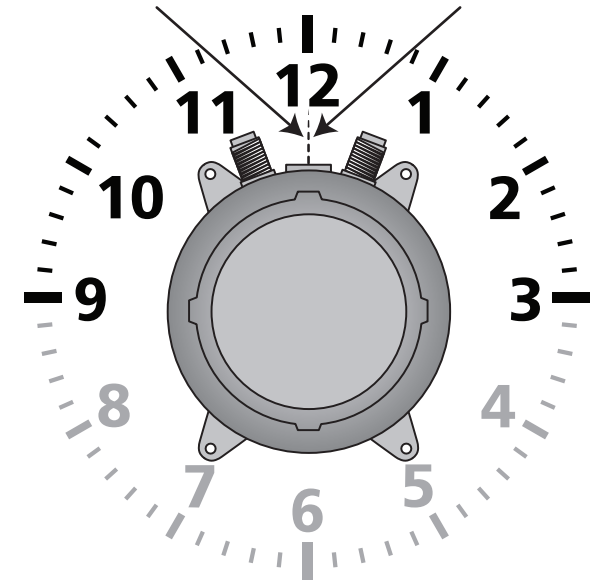

CAUTION! When mounting your compressor and/or adjusting the belt use caution. Mount by using the centerline of the oil fill plug as your guide. The compressor can **ONLY** be mounted inbetween the 9 to 3 positions. DO NOT mount inbetween the 4 to 8 positions.

This can cause compressor failure.

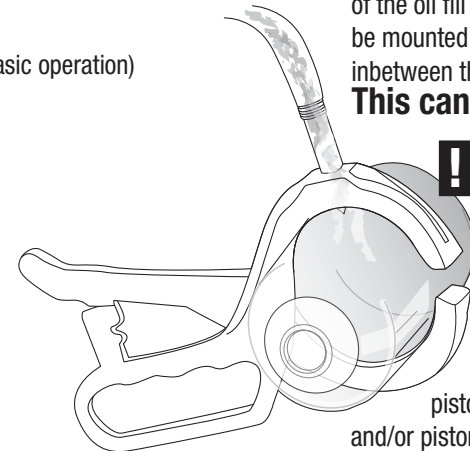

 **Do NOT tilt, shake or turn refrigerant can upside-down OR use a charging station to install refrigerant while the engine is running.** Doing so will

direct liquid refrigerant into the compressor piston chamber, causing damage to reed valves and/or pistons and/or other components, as well as potentially seizing the compressor. Allow a minimum of 30 minutes for liquid to "boil off." You must hand turn the compressor hub (not the pulley) a minimum of 15 complete revolutions prior to starting the engine with the clutch engaged.



TROUBLESHOOTING GUIDE

TEST CONDITIONS USED TO DETERMINE SYSTEM OPERATION

(THESE TEST CONDITIONS WILL SIMULATE THE AFFECT OF DRIVING THE VEHICLE AND GIVE THE TECHNICIAN THE THREE CRITICAL READINGS THAT THEY WILL NEED TO DIAGNOSE ANY POTENTIAL PROBLEMS).

- B. CONNECT GAUGES OR SERVICE EQUIPMENT TO HIGH/LOW CHARGING PORTS.
- C. PLACE BLOWER FAN SWITCH ON MEDIUM.
- D. CLOSE ALL DOORS AND WINDOWS ON VEHICLE.
- E. PLACE SHOP FAN IN FRONT OF CONDENSER.
- F. RUN ENGINE IDLE UP TO 1500 RPM.

ACCEPTABLE OPERATING PRESSURE RANGES (R134A TYPE)

1. HIGH-SIDE PRESSURES (150-275 PSI) **Note- general rule of thumb is two times the ambient (daytime) temperature, plus 15-20%.*
2. LOW-SIDE PRESSURES (10-25 PSI in a steady state).

CHARGE AS FOLLOWS: R134A = 24 OZ.

NO ADDITIONAL OIL IS NECESSARY IN OUR NEW COMPRESSORS.

TYPICAL PROBLEMS ENCOUNTERED IN CHARGING SYSTEMS

NOISY COMPRESSOR. A noisy compressor is generally caused by charging a compressor with liquid or overcharging

- A. If the system is overcharged both gauges will read abnormally high readings. This is causing a feedback pressure on the compressor causing it to rattle or shake from the increased cylinder head pressures. System must be evacuated and re-charged to exact weight specifications.
- B. **Heater control valve installation** - Installing the heater control valve in the incorrect hose. Usually when this occurs the system will cool at idle then start to warm up when raising the RPM's of the motor. **THE HEATER CONTROL IS A DIRECTIONAL VALVE; MAKE SURE THE WATER FLOW IS WITH THE DIRECTION OF THE ARROW.** As the engine heats up that water transfers the heat to the coil, thus overpowering the a/c coil. A leaking or faulty valve will

have a more pronounced affect on the unit's cooling ability. Installing the valve improperly (such as having the flow reversed) will also allow water to flow through, thus inhibiting cooling. Check for heat transfer by disconnecting hoses from the system completely. By running down the road with the hoses looped backed through the motor, you eliminate the possibility of heat transfer to the unit.

- C. **Evaporator freezing** - Freezing can occur both externally and internally on an evaporator core. External freeze up occurs when the coil cannot effectively displace the condensation on the outside fins and the water forms ice (the evaporator core resembles a block of solid ice), it restricts the flow of air that can pass through it, which gives the illusion of the air not functioning. The common cause of external freezing is the setting of the thermostat and the presence of high humidity in the passenger compartment. All door and window seals should be checked in the event of constant freeze-up. A thermostat is provided with all units to control the cycling of the compressor.
- D. **Internal freeze up** occurs when there is too much moisture inside the system. The symptoms of internal freeze up often surface after extended highway driving. The volume of air stays constant, but the temperature of the air gradually rises. When this freezing occurs the low side pressure will drop, eventually going into a vacuum. At this point, the system should be checked by a professional who will evacuate the system and the drier will have to be changed.
- E. **Inadequate airflow to condenser** - The condenser works best in front of the radiator with a large supply of fresh air. Abnormally high pressures will result from improper airflow. Check the airflow requirements by placing a large capacity fan in front of the condenser and running cool water over the surface. If the pressures drop significantly, this will indicate the need for better airflow.
- F. **Incorrect or inadequate condenser capacity** - Incorrect condenser capacity will cause abnormally high head pressures. A quick test that can be performed is to run cool water over the condenser while the system is operating, if the pressures decrease significantly, it is likely a airflow or capacity problem.
- G. **Expansion valve failure** - An expansion valve failure is generally caused by dirt or debris entering the system during assembly. If an expansion valve fails it will be indicated by abnormal gauge readings. A valve that is blocked will be indicated by high side that is unusually high, while the low side will be unusually low or may even go into a vacuum. A valve that is stuck open will be indicated by both the high and low pressures rising to unusually high readings, seeming to move toward equal readings on the gauges.
- H. **Restrictions in system** - A restriction in the cooling system will cause abnormal readings on the gauges. A high-side restriction (between the compressor and the drier inlet) will be indicated by the discharge gauges reading excessively high. These simple tests can be performed by a local shop and can help determine the extent of the systems problem.



Trouble Shooting Your Classic Auto Air A/C System

PROBLEM: system is not cooling properly

ISSUE: cold at idle, warmer when raising engine RPM's

Make sure the Water Valve is positioned correctly

The water valve is a directional valve and should be installed with the arrow pointing towards the water pump, it should be connected to the heater hose that runs from the heater core to the water pump. If the water valve is connected to the incorrect hose it allows water to circulate through the system via the heater core over powering the cooling effect of the A/C coil, (normally the air conditioning is functioning properly).

Step 1: Check placement of the water valve, correct if needed. (In some cases changing the location of the water valve may not fix the above problem.) Continue to next step.

Step 2 If changing the location of the water valve does not rectify the issue, then possibly the water valve is permanently damaged and may need to be replaced. To check the integrity of the water valve completely remove the water hoses for the heater core and "loop" together. (This will remove the heater system completely from the possibilities) If the system now cools, replace the water valve

Verify Adequate Air Flow to Condenser

For an air conditioning system to function properly there has to be adequate airflow across the condenser. The function of the condenser is to dissipate heat, without proper airflow your system will not cool correctly in the cabin of your vehicle.

Step 1: connect gauges to a/c hoses. The pressures should be: with the ambient temp is 90, low side pressures should be between 10-25 psi, high side pressures should be between 150-275 psi

Step 2: IF the low side pressures are normal and the high side pressures are high then there might be an airflow issue, continue to next step.

To test air flow to Condenser do the following three tests:

1. Place a piece of paper on the condenser with the car in idle and see if paper is held in place.
2. With car in idle, attach gages, and place a large capacity fan in front of the condenser. What happens to the pressures?
3. With car still in idle and gages attached, pour water down the front of the condenser. What happens to the pressures?

If the paper is held in place you are at least getting some air flow. If the high side decreases during test 2 & 3 then your condenser is not getting enough air which is causing your system to not cool properly. To correct this issue you will need a more powerful mechanical fan.

Step 3: Confirm correct Refrigerant charge in System

All of our systems should be charged with 24oz or 1.5lbs of R134 Refrigerant only. If overcharged you will need to evacuate the system and recharge with the correct amount.*

What measurements mean:

Low Temp and High Pressure seem to be equal...

You have a malfunctioning expansion valve that is stuck open.

High Side is extremely high and Low Side is extremely low (possibly into vacuum)...

There is a blockage in the system. Remove hoses and blow compressed air through in both directions. If pressures don't change its possible that your expansion valve is stuck closed and would have to be replaced.

***Compressor Concerns:**

This is often misdiagnosed as a problem for the system not cooling properly. If you have a noisy compressor it is due to improper charging of refrigerant. An overcharged (more than 24oz or 1.5 lbs R134) compressor can cause rattling. If charged with pure liquid there is a high probability you have bent reed valves that are causing tapping sound.

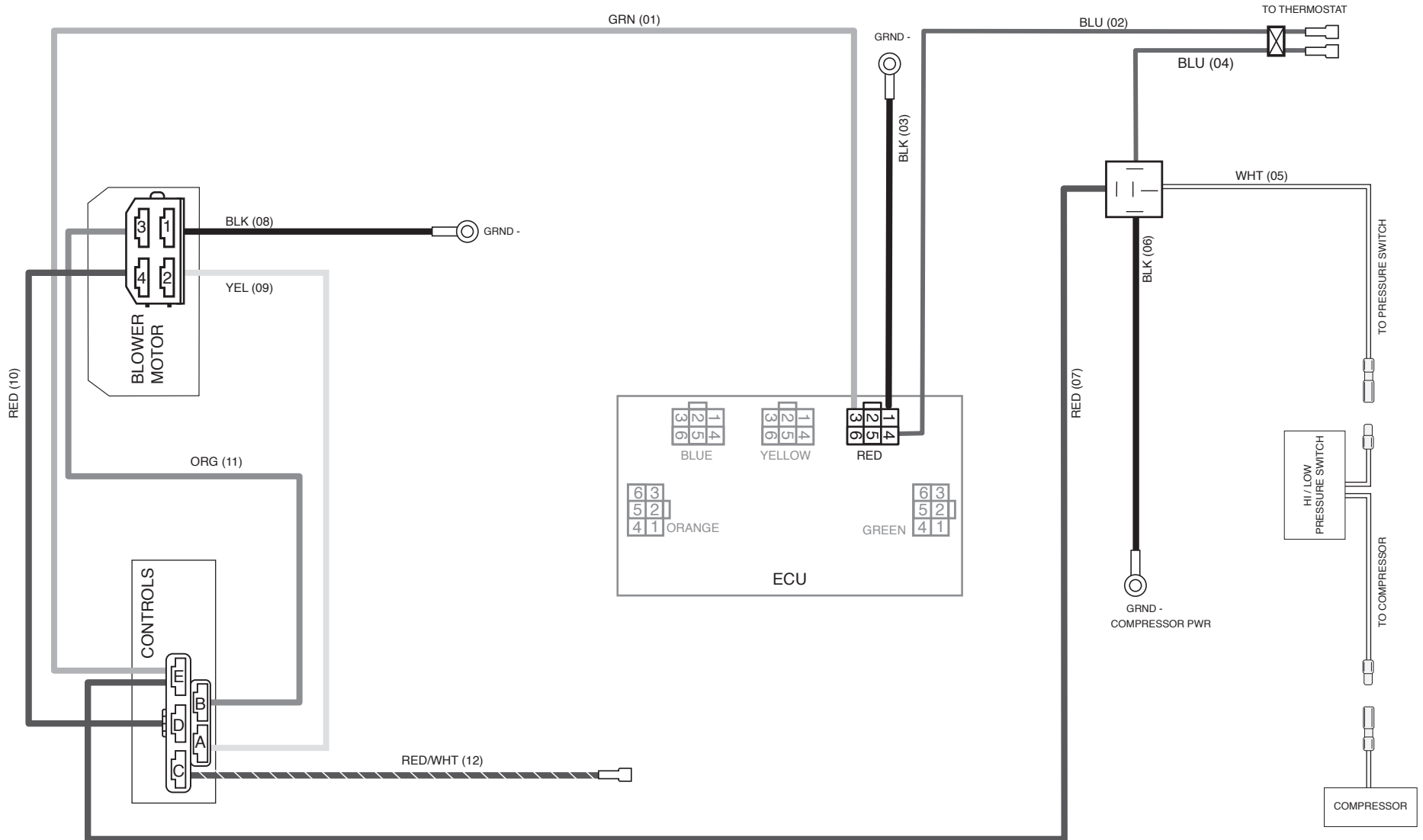

Wiring Schematic / REVERSE

