

# 40-7460L

## Compressor Bracket

Ford 429/360 w/ or w/o Power Steering

**OLD AIR** *Cooling the Classics*  
**PRODUCTS**

Division of Cold Air Products Inc.

1201 Forum Way South, Fort Worth TX 76140

817-531-2665 or FAX 817-531-3257

The 40-7460L compressor bracket is designed to mount a Sanden 508 or equivalent on the passenger side of a Ford 429/460 V-8 engine.

Installation requires a 2 Groove water pump pulley and a 3 groove crankshaft pulley.

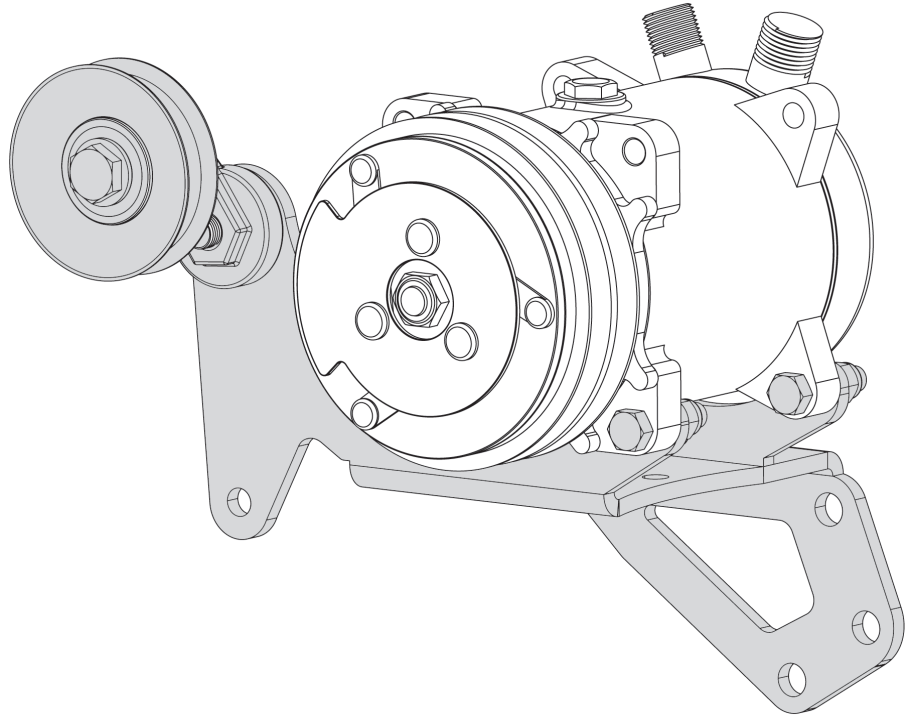

### **Remove Factory A/C Bracket** (Engines w/o A/C skip to step 7)

- 1) Evacuate and recover refrigerant from A/C system.
- 2) Disconnect Battery.
- 3) Disconnect and remove Suction and Discharge Hoses from Compressor.
- 4) Loosen tensioner and remove belt from compressor.
- 5) Remove OEM tensioner/bracket assembly (5 Bolts) and remove from engine.
- 6) Remove 4 bolts from bottom of OEM Compressor/bracket and remove from engine.

**If equipped with power steering** (Manual steering skip to step 10)

7) Loosen adjustment bolts and tensioner to relieve tension on power steering belt.

8) Loosen bottom left bolt then remove top 2 bolts on power steering bracket. This will allow power steering bracket and pump assembly to pivot downward to allow clearance to access bolts and remove OEM compressor bracket from face of cylinder head.

**Remove top 2 bolts from  
Power Steering Bracket**

**Loosen to allow P/S Bracket and  
pump to pivot downward this will  
allow clearance to remove bolts  
from original Compressor Bracket**

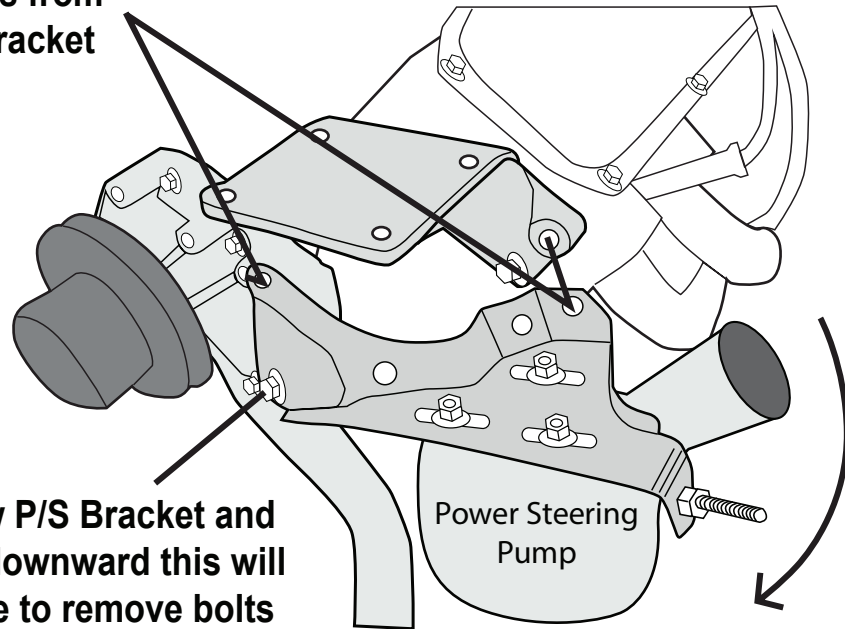

9) Remove OEM compressor bracket from engine.

10) Hold compressor bracket flat against cylinder head. Secure bracket to head with 3/8-16 X 3/4 bolt in top left hole and (3) 7/16-14 x 3/4 bolts in remaining 3 holes. **NOTE:** Hole on top right may not be required on all engines. If equipped with power steering loosely thread bolt into hole for alignment, it will be replaced with a longer bolt and spacer when power steering bracket is reinstalled.

11) Place 3/4" spacer between water pump and bracket, insert 3/8-16 x 1-1/2" bolt.

12) Tighten bolts securing bracket to cylinder head and water pump.

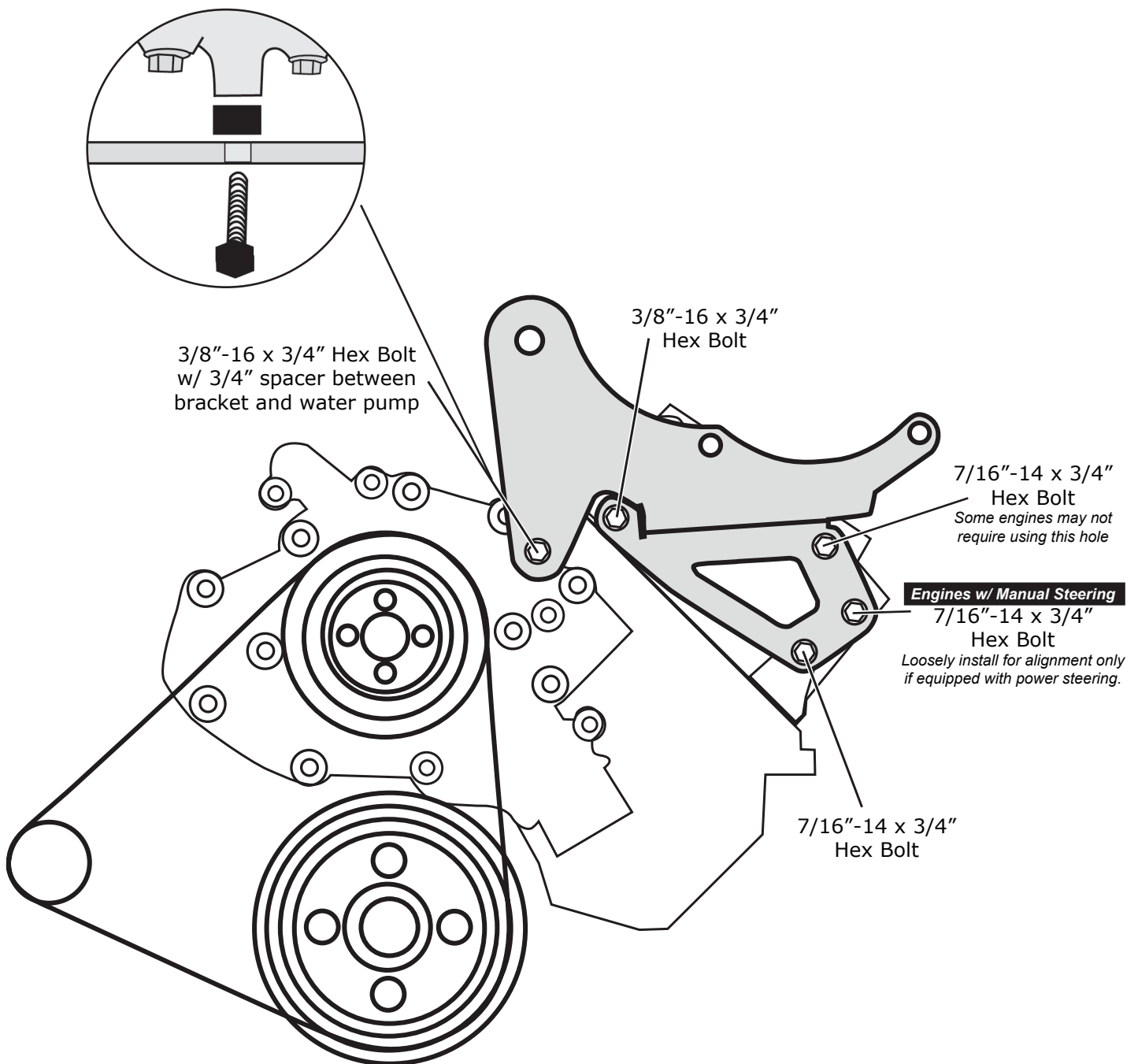

**Reinstall power steering bracket** ( if manual steering skip to step 15)

13) Remove bolt loosely inserted for alignment in step 10. Pivot power steering bracket up to original position. Using 7/16"-14 x 1-3/4" Hex Bolt, insert bolt through P/S bracket, 3/4" spacer, compressor bracket and thread into cylinder head.

14) Reinstall original bolt into left power steering bracket and tighten power steering mounting bracket.

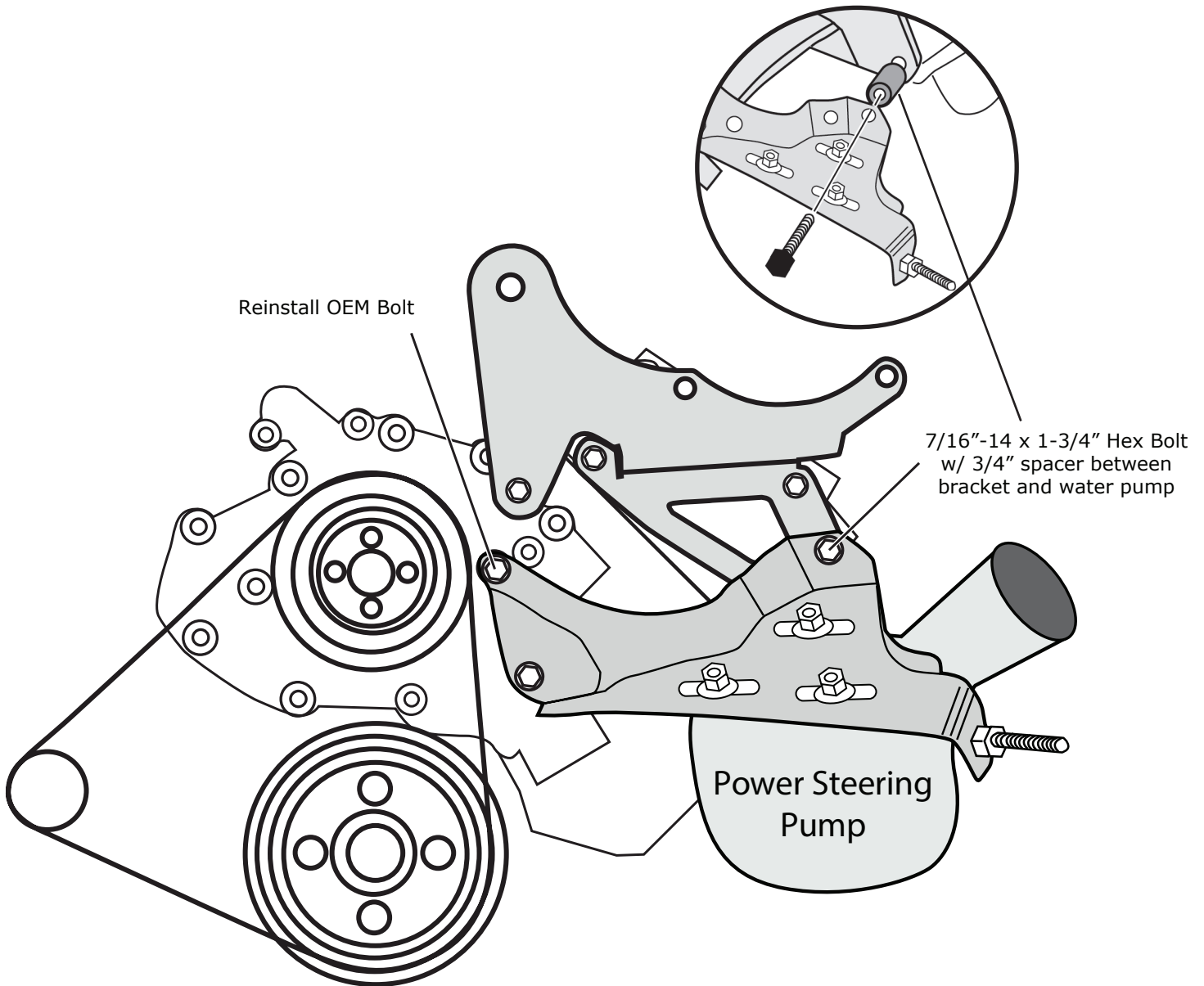

15) Assemble idler pulley assembly. Insert shoulder bolt through pulley and (2) 7/16" flat washers the thread into idler arm.

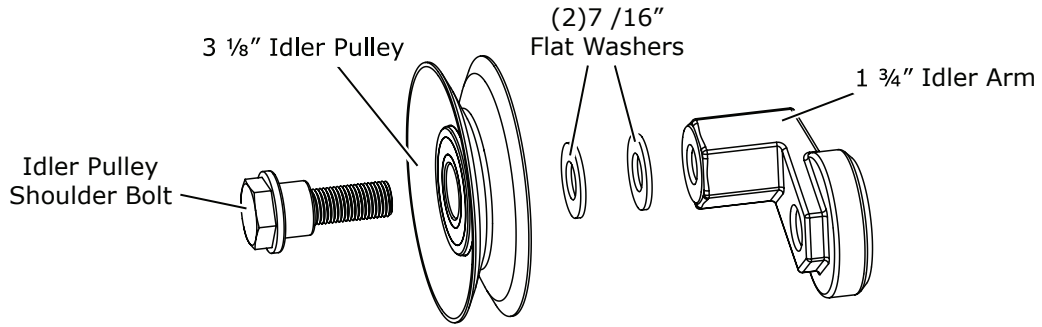

16) Attach pulley/idler assembly to bracket with 1/2"-20 x 1-1/4" Hex Bolt and 1/2" Lock Washer

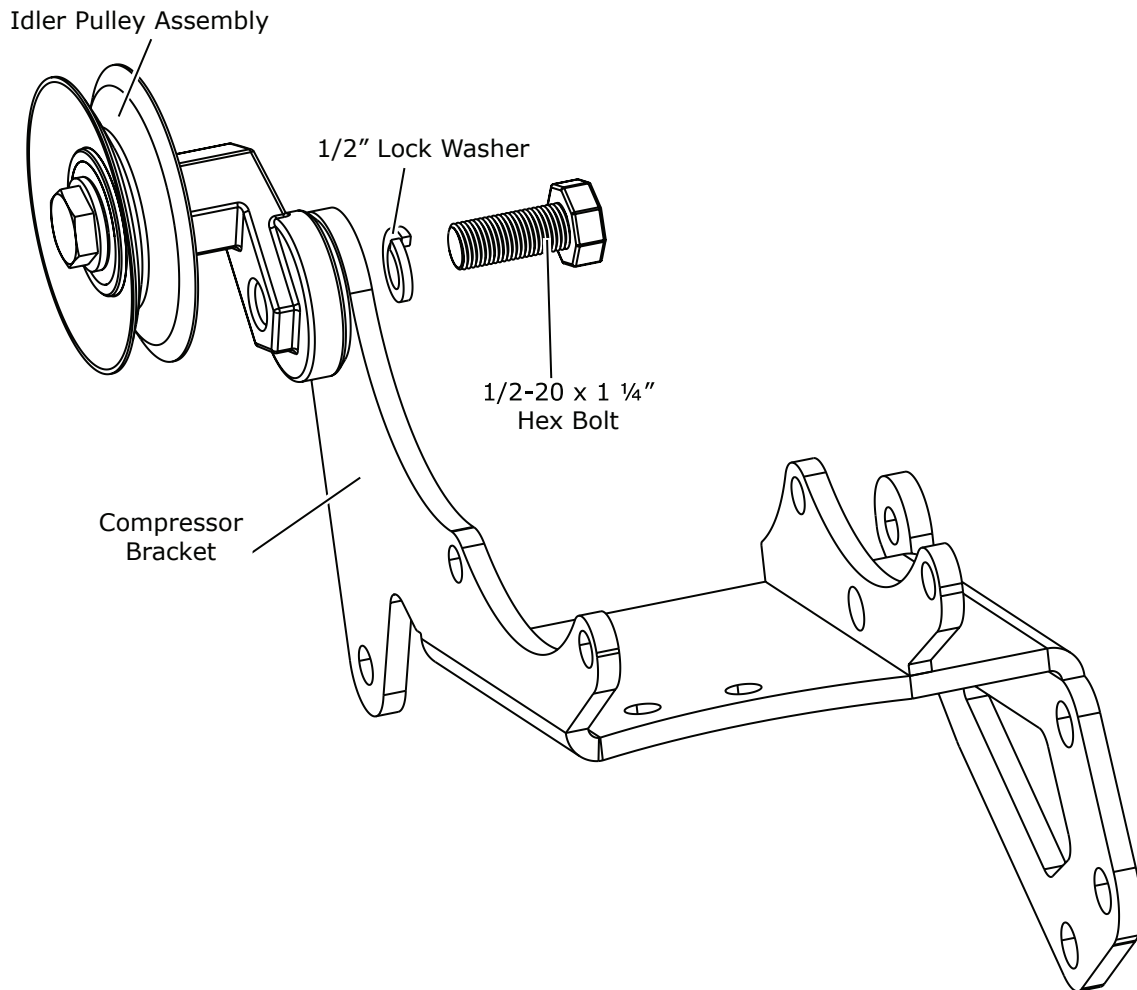

16) Mount compressor to bracket with (4) 3/8"-16 x 1-1/2" Hex Bolts and (4) 3/8"-16 Locknuts.

**NOTE:** Ears on compressor will attach to the front of the mounting tabs on the bracket. Compressor may be mounted with fittings pointed up or to the side for additional hood clearance. Do not mount with fittings pointed down!

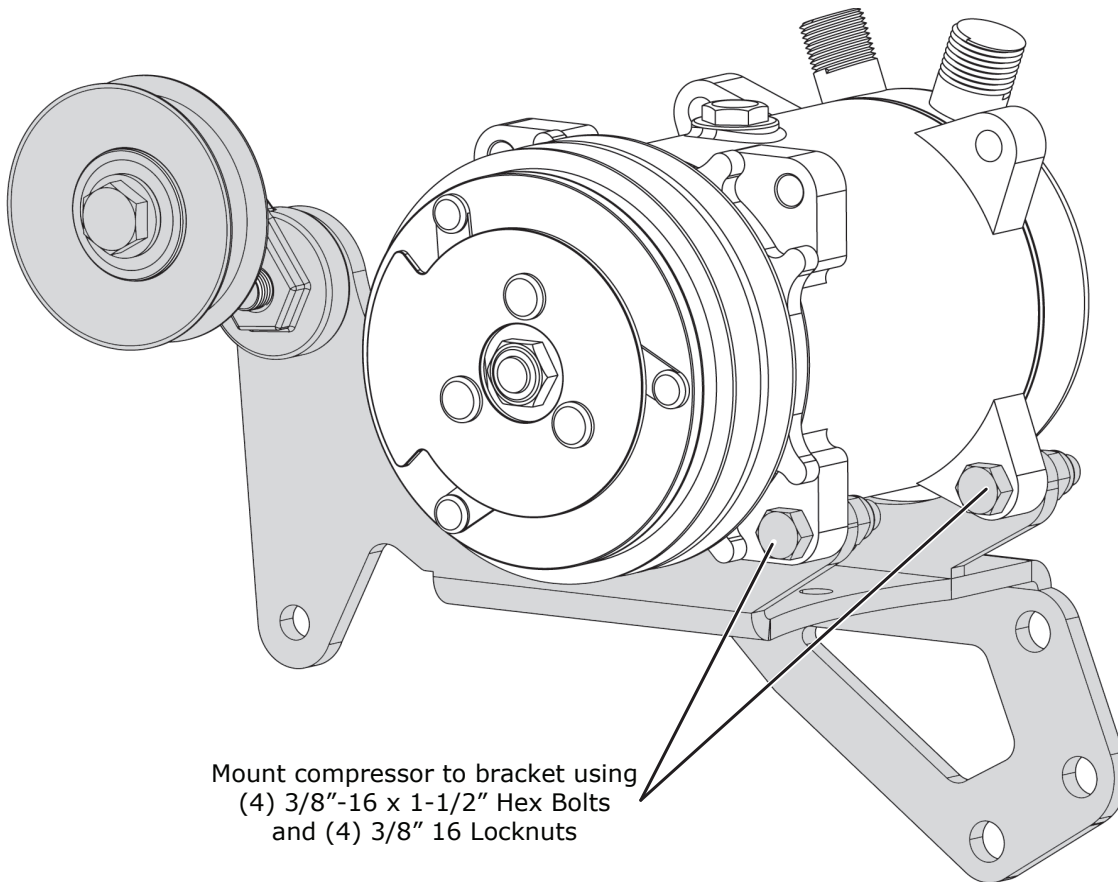

Mount compressor to bracket using  
(4) 3/8"-16 x 1-1/2" Hex Bolts  
and (4) 3/8" 16 Locknuts

17) Belt routing. **NOTE:** A compressor belt length of 54-7/8" is typical for engines with stock pulleys. However may vary depending on accessories and diameter of pulleys.

### with Power Steering

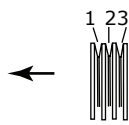
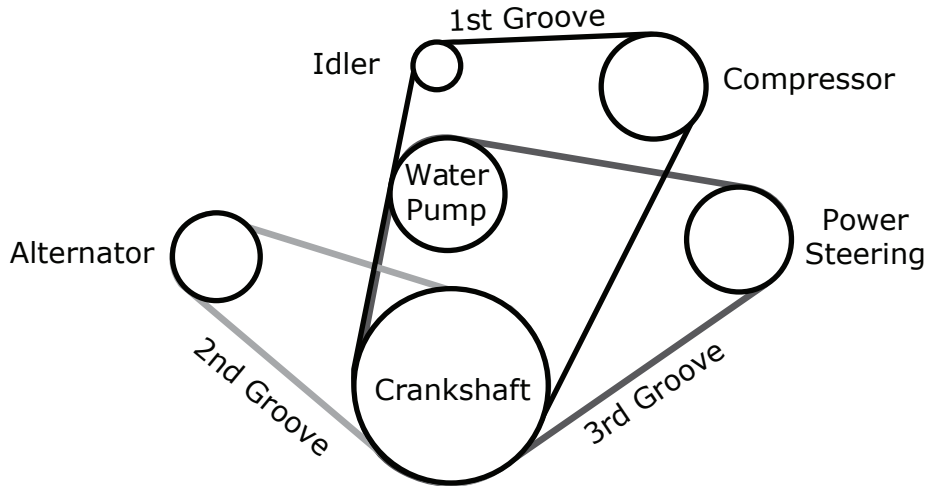

#### **Crankshaft Pulley Grooves:**

1. Crankshaft, Water Pump, Idler & Compressor
2. Crankshaft, Water Pump & Power Steering
3. Crankshaft, Alternator

### without Power Steering

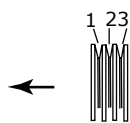
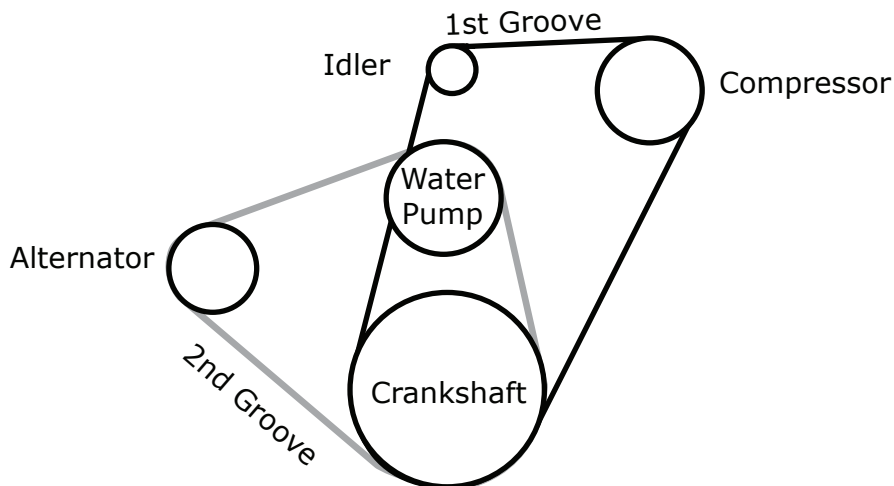

#### **Crankshaft Pulley Grooves:**

1. Crankshaft, Water Pump, Idler & Compressor
2. Crankshaft, Alternator & Water Pump
3. Crankshaft, Alternator & Water Pump